

**Cross
Country
Wireless**

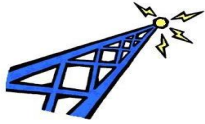

Cross Country Wireless, 7 Thirlmere Grove, BOLTON, BL4 0QB, UK

Email chrism@crosscountrywireless.net
Web page <http://www.crosscountrywireless.net>
Telephone +44 (0) 1204 410626
Mobile GSM 900 +44 (0) 7752 391908



SDR Receiver

Operating Manual

version 1.8

Partners: Mr C.J.Moulding, Mrs S.M.Moulding



Contents

- 1 SDR Receiver
- 2 Specification
- 3 Receiver hardware
- 4 Operating with Rocky software
- 5 Operating with M0KGK SDR software
- 6 Operating with PowerSDR software
- 7 Schematic diagrams
- 8 Modification for use with high spec sound cards
- 9 EC Declaration of Conformity



1 SDR Receiver

The Cross Country Wireless SDR Receiver is a compact high performance HF software defined radio receiver designed to be used in fixed or portable stations.

It has a choice of two internal crystal oscillators or an external VFO, it's got good RF filtering (high and low pass filters similar to our VHF/UHF filters) before the front end and it's optimised for use with any stereo input sound card so you won't need to buy an expensive sound card to use it.

The 40 / 30m version has centre frequencies of 7.057 MHz and 10.125 MHz.

The 30m version has a narrower front end band pass filter and centre frequencies of 10.125 and 10.140 MHz.

The 80m version has centre frequencies of 3.580 and 3.668 MHz.

Using a 48 kHz sound card, SDR software can tune +/- 24 kHz from the centre frequency.

Features include:

- High performance software defined receiver
- Dual band 40 / 30m or monoband 30m and 80m versions
- Two crystal oscillators and an external VFO input
- RF band pass filter in receiver front end
- Optimised for low cost stereo sound cards
- Minimum signal detectable is better than -127 dBm with a 48 kHz 16 bit sound card
- Expensive sound card not required for operation
- Compatible with SDR software designed for Softrock receivers (Rocky, PowerSDR, WinRad, M0KKGK SDR, SDR-Radio)
- No surface mount components
- Supplied built, aligned and tested
- Power requirements 7 to 25V current consumption 60 mA
- Meets EU specifications for EMC, RoHS and WEEE
- Built to last with high grade components in a tough ABS case

I hope you enjoy using the Cross Country Wireless SDR Receiver!

73,

Chris Moulding, G4HYG

2 Specification



SDR Receiver

| | | |
|---------------------------|--|--------------------|
| Input impedance | 50 ohms | |
| RF Cable connector | BNC female | |
| AF output impedance | 1000 ohms | |
| Minimum Detectable Signal | Better than -127 dBm using a 48 kHz 16 bit stereo sound card with Rocky 3.6 SDR software | |
| Power connector | 2.5mm centre pin DC power connector (positive pin, negative outer) | |
| Size (overall) | 150mm x 112mm x 35mm | 5.9" x 4.4" x 1.3" |
| Power requirements | 7 to 20V, 60mA negative earth | |
| Centre frequencies: | | |
| 40 / 30m SDR receiver | 7.057 MHz and 10.125 MHz | |
| 30m SDR receiver | 10.125 MHz and 10.140 MHz | |
| 80m SDR receiver | 3.580 and 3.668 MHz | |
| RF filtering 40/30m | < 3.5 MHz better than 60 dB >14 MHz better than 40 dB | |
| RF filtering 30m | < 4 MHz better than 60 dB > 14 MHz better than 40 dB | |
| RF filtering 80m | <1.5 MHz better than 60 dB >7 MHz better than 40 dB | |
| Spurious output | <-40 dBm at the antenna terminal (typically -47 dBm maximum) | |

The SDR Receiver meets the requirements of EC Directives EN50082-1 EMC Generic Immunity Standard (Residential, Commercial and Light Industrial), RoHS (Restriction of Hazardous Substances) and WEEE (Waste Electrical and Electronic Equipment). The SDR Receiver is marked with a CE mark.

3 Receiver hardware

Crystal jumpers
X1
X2
External VFO

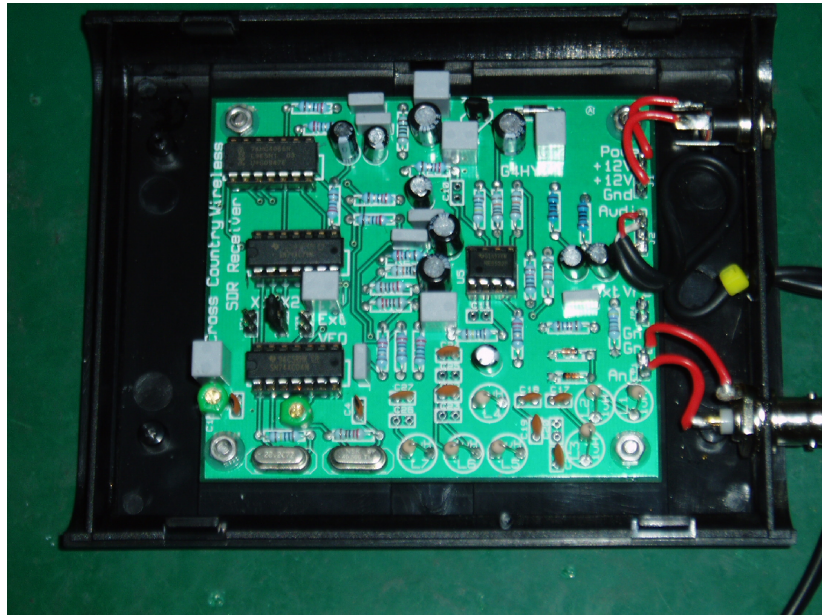

2.5mm DC power
connector, positive
pin, negative
shield

I/Q audio output to
3.5mm stereo jack

BNC antenna

4 Operating with Rocky

Download and install Rocky v3.6 on your PC.

Connect the 3.5mm audio cable from the SDR Receiver to the stereo Line or Mic input of your PC sound card.

Connect antenna and 12V supply to the SDR Receiver.

Open Rocky 3.6.

Open View/Settings/Audio in Rocky 3.6 to select the correct sound card and appropriate settings.

Open View/Settings/DSP to set the Local Oscillator frequency.

Press the Start Radio button.

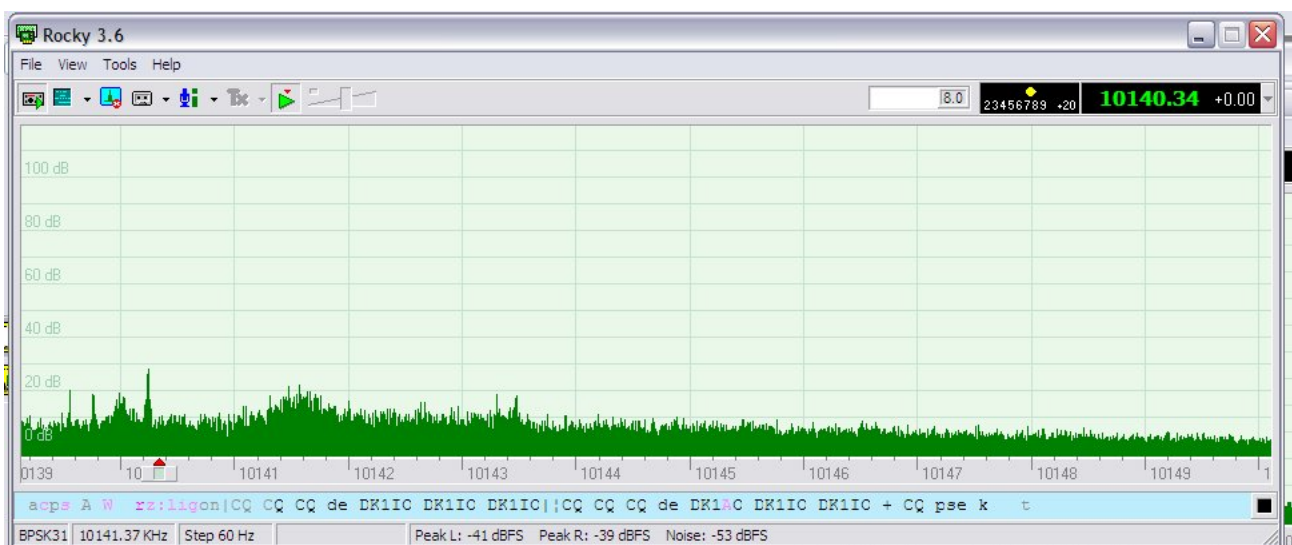
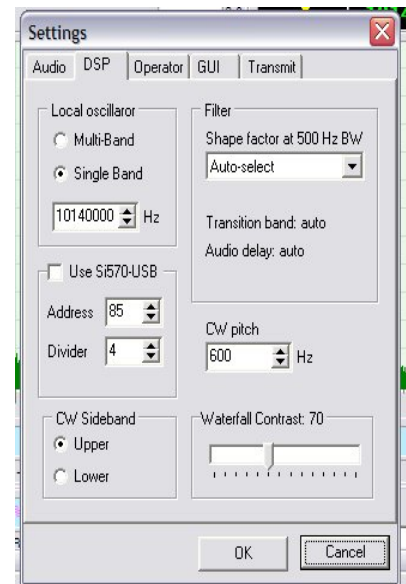
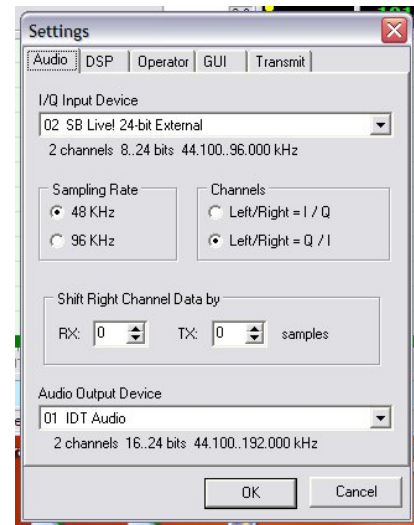



5 Operating with M0KDK SDR software

To be added soon...

6 Operating with PowerSDR software

To be added soon...

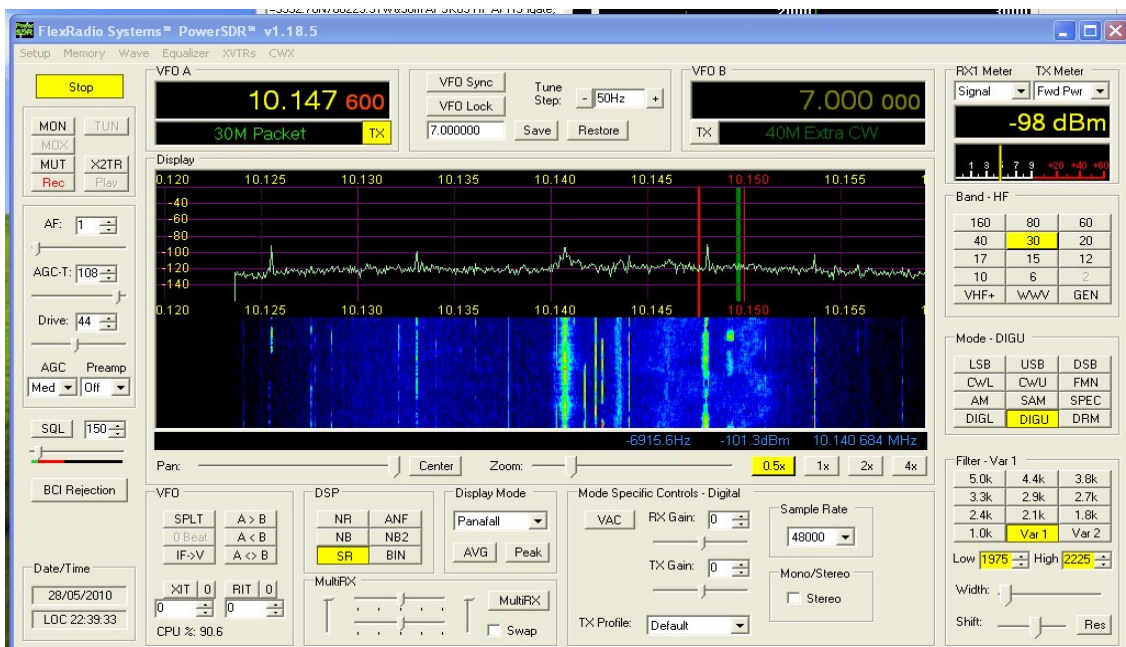

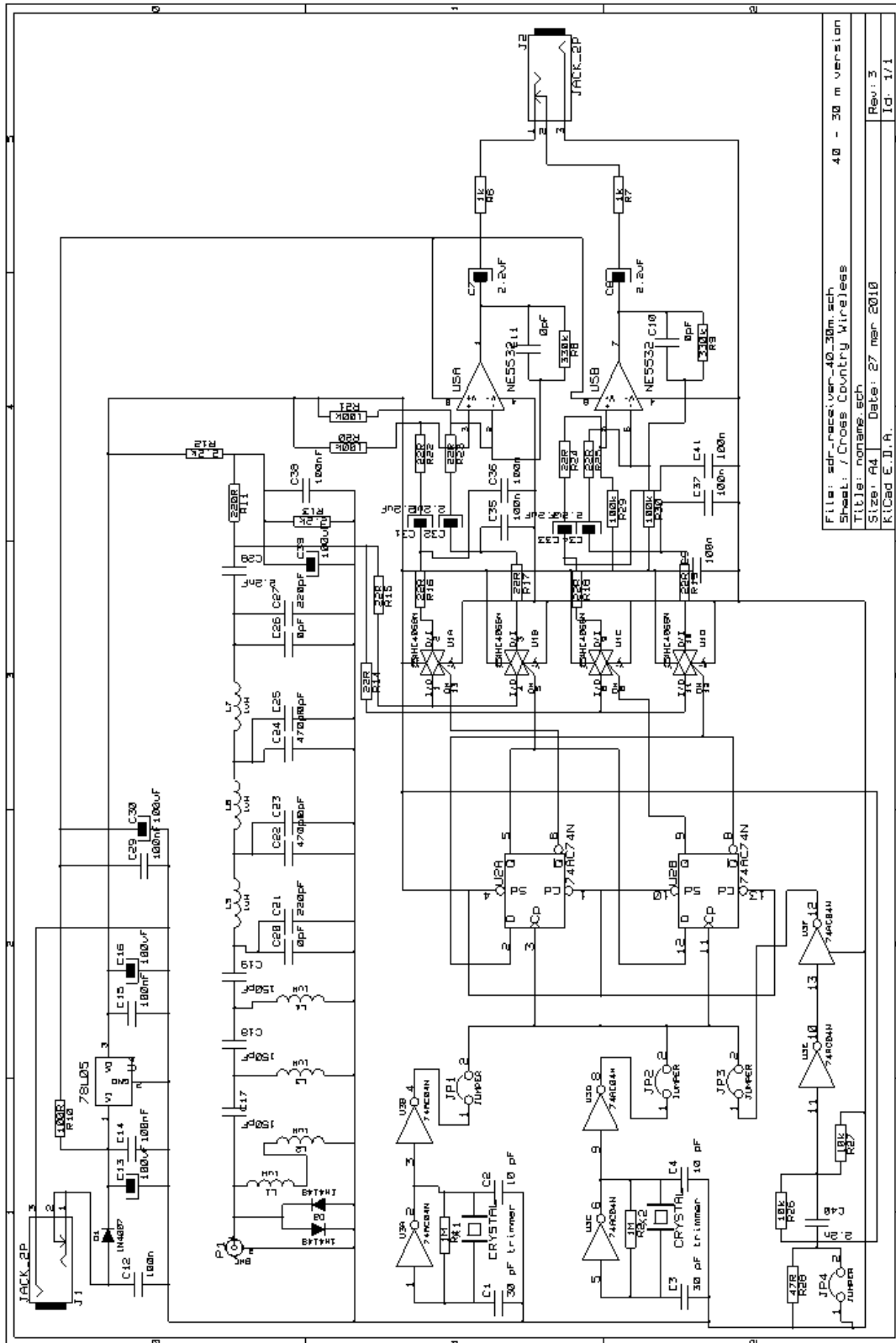
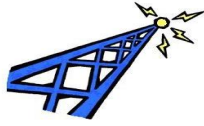

File: sdr_receiver_40_30m.sch
 Sheet: 7 Cross Country Wireless
 Title: nonans.sch
 Size: A4 Date: 27 mar 2010
 Rev: 3
 Id: 1/1

7 Schematic diagram – 40 / 30m version

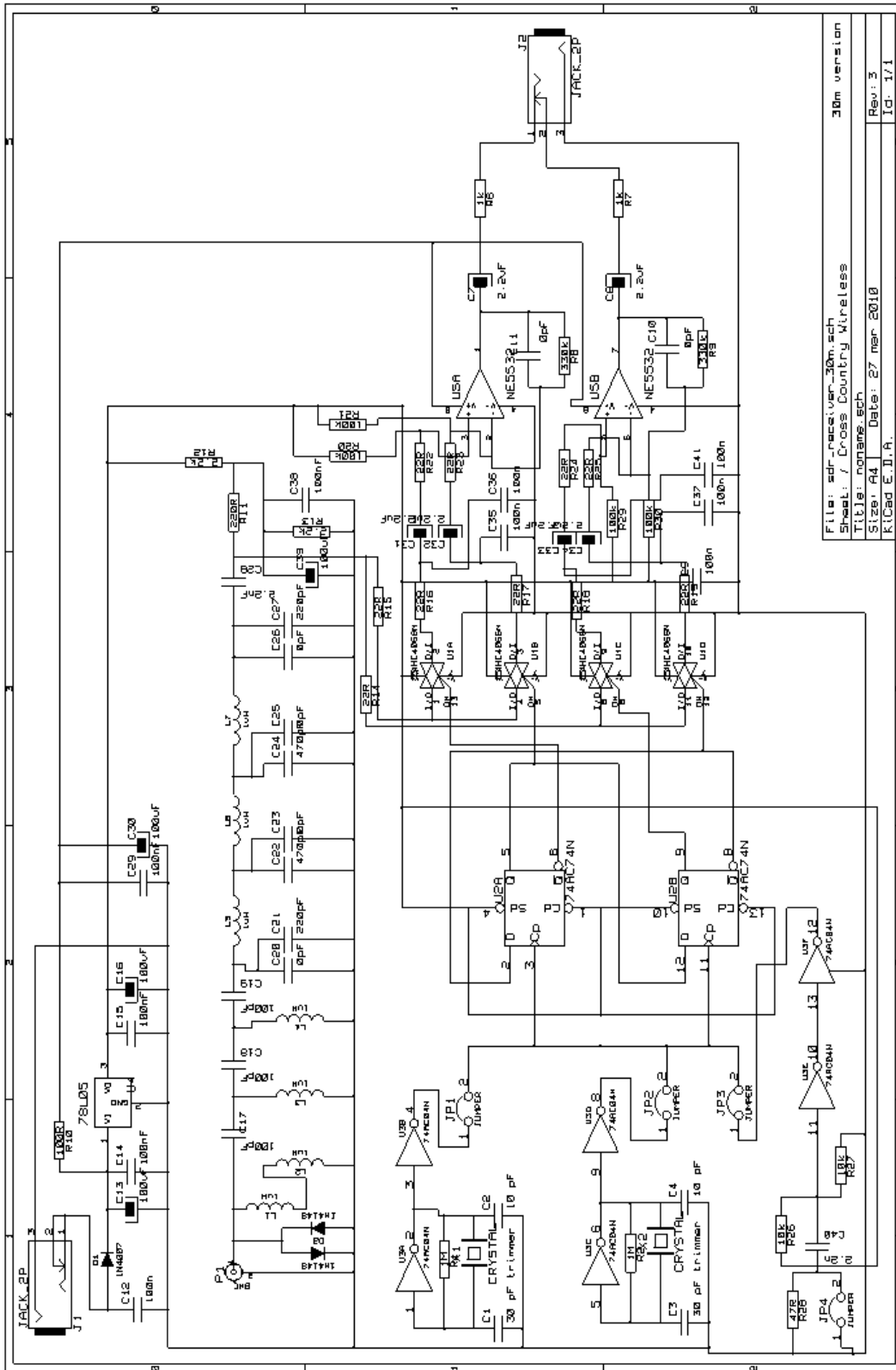
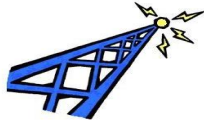

File: sdr_receiver_30m.sch
 Sheet: / Cross Country Wireless
 Title: nomans.sch
 Size: A4 Date: 27 mar 2010
 KiCad E. I. A. Rev: 3
 1 of 1

Schematic diagram – 30m only version

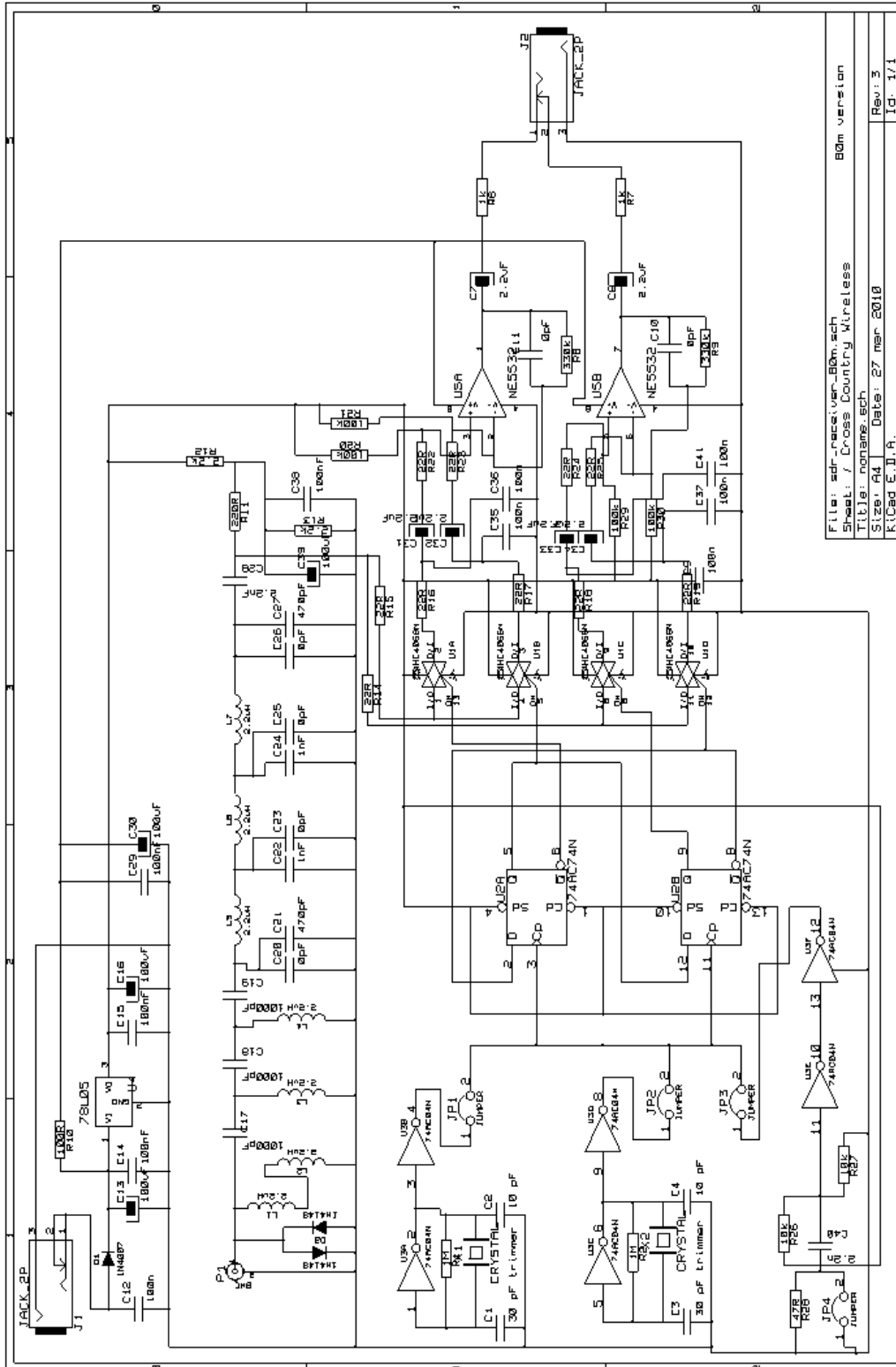
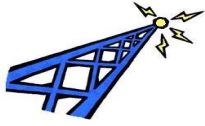

File: sdr_receiver_80m.sch
 Sheet: 7 Cross Country Wireless
 Title: none.sch
 Size: A4 Date: 27 mar 2010
 K.Cad E.I.A.
 Rev: 3
 IG: 1/1

Schematic diagram – 80m version

8 Modification for use with high spec sound cards

The CCW SDR Receiver has been specifically designed to work as a high performance HF receiver with the stereo input sound cards usually found installed as standard in desktop PCs.

The audio gain of the I/Q amplifier is higher than may be considered normal in other SDR receivers and users have asked how the audio gain may be reduced to improve performance with high performance sound cards such as the Delta-44 and Edirol.

This can be easily done by installing 2k2 ohm (2200 ohm) resistors in the C10 and C11 positions on the PCB. These positions are usually empty as C10 and C11 are only installed on receivers requiring an audio low pass option.

We recommend that the resistors are metal film 1% 0.25W specification to match the other resistors used in the receiver.

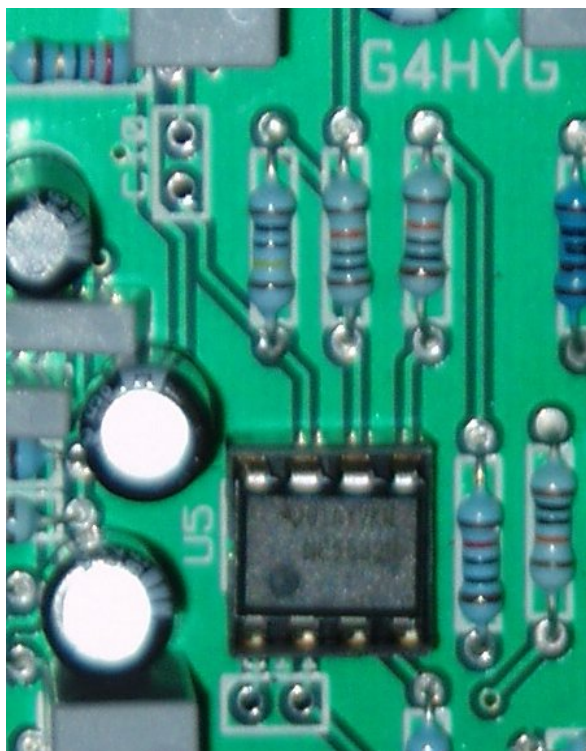

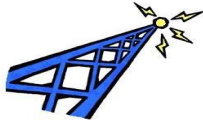

9 EC Declaration of Conformity

**Cross
Country
Wireless**



Cross Country Wireless, 7 Thirlmere Grove, BOLTON, BL4 0QB, UK

Email chrism@crosscountrywireless.net
Web page <http://www.crosscountrywireless.net>
Telephone +44 (0) 1204 410626
Mobile GSM 900 +44 (0) 7752 391908

EC Declaration of Conformity

in accordance with EN ISO 17050-1:2004

We: Cross Country Wireless

of: 7 Thirlmere Grove, Bolton, BL4 0QB

in accordance with the following Directive(s):

2006/95/EC The Low Voltage Directives
2004/108/EEC The Electromagnetic Compatibility Directives

hereby declare that

Equipment: SDR Receiver
Model number: All models

is in conformity with the applicable requirements of the following documents

| Ref no | Title | Edition / date |
|------------------|--|----------------|
| SI 1994No. 3260 | The Electrical Equipment (Safety) Regulations 1994 | 1994 |
| SI 2006 No. 3418 | The Electromagnetic Compatibility Regulations 2006 | 18/12/2006 |

I hereby declare that the equipment named above has been designed to comply with the relevant sections of the above referenced specifications. The unit complies with all applicable Essential Requirements of the Directives.

Signed by: 

Name: Christopher John Moulding
Position: Partner of Cross Country Wireless
Done at: Bolton, Lancashire
On: 23 May 2010



Attention!

The attention of the specifier, purchaser, installer, or user is drawn to special measures and limitations to use that must be observed when these products are taken into service to maintain compliance with the above directives. Details of these special measures and limitations to use are available on request, and are also contained in the product manuals.

Partners: Mr C.J.Moulding, Mrs S.M.Moulding