

# The Wave Antenna

## A New Type of Highly Directive Antenna

BY HAROLD H. BEVERAGE, CHESTER W. RICE, and EDWARD W. KELLOGG

of the Radio Corporation of America

Assoc. A. I. E. E.

Assoc. A. I. E. E.

of the General Electric Co.

of the General Electric Co.

**of the Subject.** — A small bungalow in a grove of oak outside of Riverhead, Long Island, with a line of poles unbury road, carrying two copper wires, and ending by a mile southwest of Riverhead, — this in brief describes the last "ear" of the Radio Corporation of America, where the messages from England, France, Germany and Norway are sent, amplified, converted into current of telephonic and automatically relayed over telephone circuits to the Office in New York, where operators take the messages by automatic recorders mark the dots and dashes on tape.

The present paper deals with the two copper wires on the line of which constitute the wave antenna which has not only marked advance in the reduction of interference and "static," but its aperiodic nature and effectiveness as an energy col-

made possible the simultaneous reception of a large message by one antenna, and the automatic relaying of it over land wires.

of two wires is not an essential feature of the wave antenna; its flexibility in the location of the receiving station. In its form the wave antenna consists of a straight horizontal (See Fig. 10) of the order of a wave length long, parallel to the direction of propagation of the desired signal, with the receiving end at the end farthest from the sending station and with the sending station grounded through a resistance of value to practically prevent reflections. Under these conditions the desired signal waves produce comparatively feeble currents at the end nearest the sending station and strong currents at the end, while disturbances coming from the opposite direction produce feeble currents at the receiver end and strong currents at the end farthest from the receiver (nearest the transmitting station) (See Fig. 10).

This comparative immunity of the receiving set to disturbances coming from a direction opposite to the desired signal is due to reflections are permitted to occur at the end farthest from the sending station. The growth of current in the direction of travel of the space wave is on the velocity of propagation of waves on the antenna is in phase with the velocity of the space waves, the received current is greatest if the two are equal. If the characteristic wave length of the antenna is less than that of the space waves (or less than the velocity of light) increasing the length of the antenna increases the received current up to a certain point, after which further increase in antenna length reduces the received current.

The position for maximum signal depends on the velocity ratio and the antenna length. The slower the antenna or the shorter the wave length the shorter the length for maximum signal. It is very interesting in the case, however, that the best directive properties are obtained with an antenna longer than that which gives the strongest

effect of the space wave is to produce in the wire a signal electromotive force which affects the different parts of the antenna progressively as the space wave passes over the line. On this received current can be calculated in terms of the free space wave electromotive force, the direction of the space waves and the length and electrical constants of the antenna. By assuming the direction to be changed while all other

factors remain the same, and calculating the relative value of received current for various directions of signal wave, we can determine the directive properties of the antenna. The result is best shown by means of a polar directive curve. For each assumed direction for which the received current has been calculated, a radius is drawn, with length proportional to the received current. The curve drawn through the ends of these radii is known as the directive curve for the antenna. Directive curves are given (Figs. 35 to 41) which bring out the effects of antenna length, relative to the wave length, velocity of propagation, and line attenuation. The directive curves are for the most part drawn with the maximum radius taken as unit length, since this makes comparisons of directive curves easier. In general, it is found that moderate line losses are not appreciably detrimental to the directive properties of the antennas, while the fact that velocities obtainable with unloaded lines are materially below that of light, results in an actual improvement in directive properties in most cases. As a rule the longer the antenna the sharper its directive curve. While it is possible to obtain fair directive properties with antennas less than a half wave length long, this length is considered about the shortest that can be recommended.

By a process of balancing, it is possible to produce a "blind spot" or direction of zero reception, at any angle more than 90 deg. from the signal. One method of obtaining this result is by producing reflections of certain phase and intensity at the end opposite to the receiver. Reflections at the receiver end of the antenna, on the other hand, do not alter the directive properties of the antenna.

Experimental work thus far has given a qualitative check on the theory and calculations of the wave antenna, and it is hoped that further observations and measurements will shortly be made. Experimental data on wave front tilt, on which the action of the wave antenna depends, is especially meagre.

Data on wave velocity and line losses on an existing antenna can be obtained by means of a radio frequency oscillator and one or two hot-wire milliammeters. Measurements taken by the writers show much higher attenuation and lower velocities for ground return circuits than for metallic circuits. Ground resistance explains this effect. The mean depth of return currents at the longer radio wave lengths appear to be of the order of several hundred feet. The more wires in multiple in the antenna, the lower the velocity and the higher the rate of attenuation (See Fig. 66 and 68).

Reduction of atmospheric disturbances or "static", has probably received more attention from experimenters than any other one phase of radio reception. Of the various lines of attack none has been more fruitful than the employment of directive receiving systems. Every increase in directivity has resulted in an improvement in stray ratio. The wave antenna carries the principle farther than any previous type. Conditions on the eastern coast of North America are especially favorable for taking advantage of differences in direction, for the European stations are to the northeast while the predominating direction of static is from the southwest.

Various practical engineering problems in connection with the wave antenna, including its application to short wave reception, are discussed toward the close of the paper.

### HISTORICAL

The wave antenna is a long horizontal antenna and therefore belongs to the class of antennas usually referred to as ground antennas, of which it is an

The first work with long horizontal antennas appears to have been done in the pioneer days of radio by Marconi<sup>1</sup>, Braun<sup>2</sup>, Secher<sup>3</sup>. A short historical sketch

1. Marconi, English Patent No. 12039, 1896.
2. F. Braun, D. R. P. No. 115081, 1898.
3. E. Secher, *Phys. Ztschr.*, 4, 320, 1903.

presented at the Midwinter Convention of the A. I. E. E., New York, February 14-17, 1923.

of ground antenna work is given by Zehnder<sup>4</sup> who was also an early worker in this field.

More recently Kiebitz<sup>5</sup> has studied the transmission and reception using certain forms of ground antennae. A discussion of the operation has been given by Burstyn<sup>6</sup>. Further experiments and comments on the operation of ground antennae are given by Kiebitz, Burstyn, Hansrath, Mosler<sup>7</sup>.

In this country early work was done by Clark, Rogers and Taylor. This work has been recorded in the classical papers by Taylor<sup>8</sup>.

Alexanderson's<sup>9</sup> barrage receiver made use of ground antennae and may be considered as the starting point of our work.

The capabilities of the wave antenna were discovered through work done by Beverage in studying the properties of long ground antennas, of the order of a half wave length or more long, in which he discovered that under certain circumstances they showed marked unidirectional properties. One of his antennas consisted of a No. 14 B & S rubber covered wire approximately six miles long laid on the scrub oak and sand of Long Island from Eastport to a point near Riverhead. This northeasterly direction was chosen in order to best receive the European stations. The antenna is pictured diagrammatically in Figure 1.

With the receiving set connected between the antenna and ground at the Eastport end and with the Riverhead end grounded, Beverage observed strong signals from Europe, but when the conditions were reversed and the receiver was inserted at Riverhead the European signals were very weak and the static and stations to the southwest were strong. This marked unidirectional property of the antenna was found only when the end opposite to the receiver was grounded.



FIG. 1

Beverage next investigated the effect of antenna length by listening in series with the antenna at different points along the antenna. The receiver was mounted in a Ford truck and trips were made back and forth along the antenna, stopping to listen at approximately every mile. By this process the observations given in Fig. 2 were obtained.

In commenting on these observations Beverage's log reads - - - - "It is evident that the antenna is too

long for maximum reception at the S. W. end. It be due to the fact that the velocity of the current in wire is considerably slower than the velocity of light and the currents from remote parts of the antenna in phase behind currents from parts of the antenna the receiver. If so, condensers, distributed along line, could be used to increase the velocity of current flowing in the wire and make the velocity the same as the velocity of light." By inserting series condenser in the line Beverage found that he could shift the position of the points at which the signal maxima occur and thus utilize longer antennas.

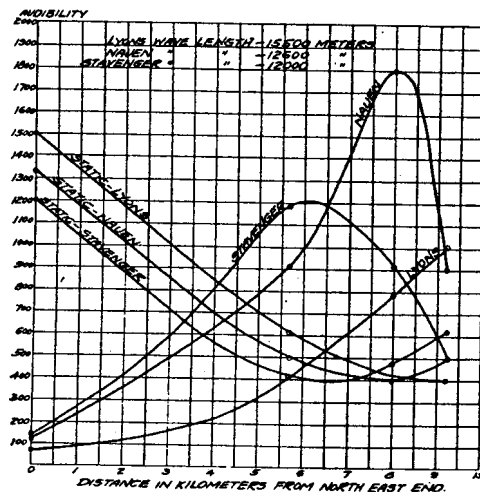

FIG. 2—GROWTH OF SIGNAL CURRENTS IN LONG HORIZONTAL ANTENNA

At about this point in the work Mr. Alexanderson called Rice's attention to Beverage's important discovery. Rice and Kellogg, before learning of the results of Beverage's work, had concluded on purely theoretical grounds that a long horizontal antenna, pointed in the direction of a sending station, would constitute a unidirectional receiver provided the receiver was placed at the end of the antenna remote from the sending station, while the end nearest the transmitting station was grounded through a non-inductive reactance, equal to the surge impedance of the antenna. If open or dead grounded at the end nearest the transmitter, reflections would occur, and the antenna should show bidirectional properties. Rice explained his theory of the operation to Mr. Alexanderson, suggesting that the necessary damping required to make the antenna unidirectional was due to the resistance of ground connections combined with the high attenuation to be expected in an antenna of No. 14 B & S rubber covered wire lying on the sandy soil and bushes.

At Mr. Alexanderson's request, Rice joined Beverage at Eastport, and a study was made of the properties of the rubber covered lines by means of an oscillator. They also made listening tests which indicated some resistance, in addition to the ground resistance, was best for unidirectional effects.

The use of the oscillator made it possible to determine

4. L. Zehnder, *Jahrb. d. drahtl. Tele.*, Vol. 5, 1911, p. 594.  
 5. F. Kiebitz, *Jahrb. d. drahtl. Tele.*, Vol. 5, 1911, p. 349, Vol. 6, 1912 p. 1 and p. 554. Also *Electrician*, Vol. LXII, p. 972 and Vol. 68, 1912 p. 868, 936, 978, 1020.  
 6. W. Burstyn, *Jahrb. d. drahtl. Tele.*, Vol. 6, 1912, p. 10 and 333.  
 7. *Jahrb. d. drahtl. Tele.*, Vol. 6, 1912, p. 359 and p. 570.  
 8. A. Hoyt Taylor, *I. R. E.*, Vol. 7, 1919, p. 337 and p. 559.  
 9. E. F. W. Alexanderson, *I. R. E.*, Vol. 7, 1919, p. 363.

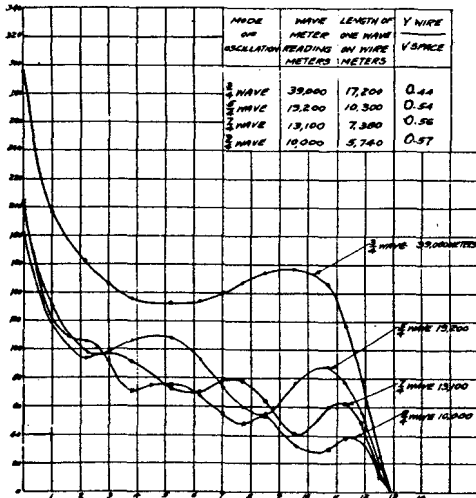

MODE OF OSCILLATION	WAVE LENGTH OF WAVE IN WIRE METERS	LENGTH OF WAVE IN WIRE METERS	V SPACE
1st WAVE	27,800	17,500	1.74
2nd WAVE	20,600	17,200	0.835
3rd WAVE	14,600	10,300	0.706
4th WAVE	11,000	7,380	0.671
5th WAVE	8,200	5,740	0.624

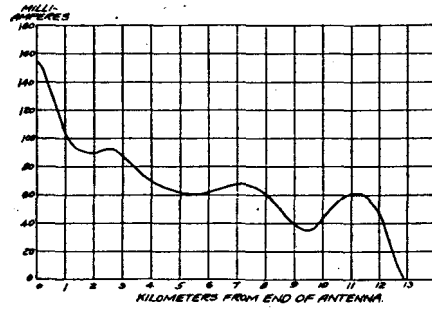

MODE OF OSCILLATION	WAVE LENGTH OF WAVE IN WIRE METERS	LENGTH OF WAVE IN WIRE METERS	V SPACE
1st WAVE	57,000	25,800	0.45
2nd WAVE	28,000	12,300	0.48
3rd WAVE	18,000	8,400	0.48
4th WAVE	12,500	6,450	0.52

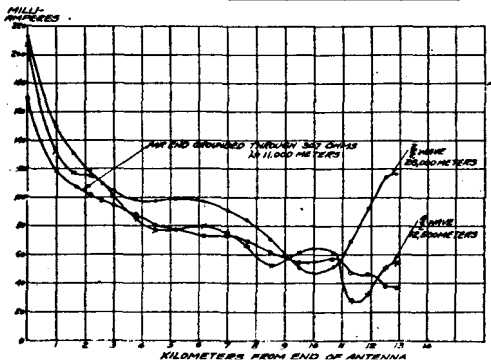

given by Mr. P. S. Carter and Mr. R. D. Greenman.

### THE NEW RIVERHEAD ANTENNA



6 shows a photograph of part of the line. A flexible type of line construction was adopted which would make it possible to try numerous experiments such as a series of loops or series of verticals connected through a transmission line, etc. Two cross arms were provided, one at a height of 18 feet and the other 30 feet above ground. The upper arm carried two No. 10 B & S copper wires and the lower arm four similar wires. All lines were broken every ten poles, and down leads were

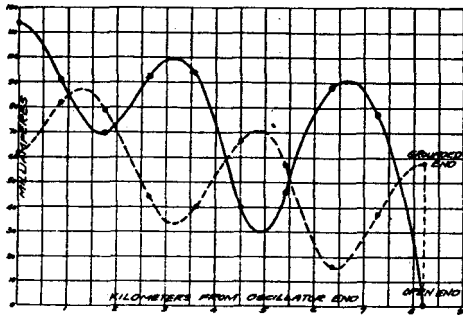

FIG. 7—OSCILLATION TESTS OF RIVERHEAD ANTENNA. FOUR WIRES IN MULTIPLE.  $\lambda = 9400$

provided so that connections could be readily changed. The line ran seven miles approximately southwest from Riverhead along an unfrequented sand road, and was later extended to Terrell River, making a total length of nine miles. The line is as straight as it was feasible to build it, and its direction is substantially in line with the principal European long wave stations, the reception of which was a matter of primary interest.

The first tests on the new line showed that the hoped.

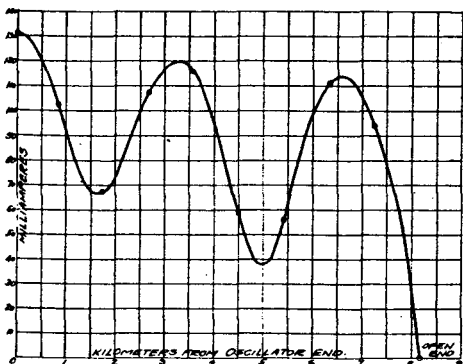

FIG. 8—OSCILLATION TESTS OF RIVERHEAD ANTENNA. TWO UPPER WIRES IN MULTIPLE.  $\lambda = 7900$

for results had been realized. Instead of an optimum length of six or seven kilometers, the signals became stronger and stronger as the receiving set was moved toward the southwest, and the signal strength there was several times greater than had been obtainable with the rubber covered antennas. While the stray ratios observed on the rubber covered antennas had seemed excellent, the new antenna fully met our expectations of improvement.

Oscillator tests on the new antenna showed that the

velocity was high and attenuation low compared with the rubber covered wires, and that it had no serious reflection points. Figs. 7, 8 and 9 show typical curves obtained with the new antenna. A comparison with similar curves, taken on the rubber covered ground wires, brings out the improved electrical properties.

The failure at the start to get good short circuit reflections when the far end of the line was grounded caused us to suspect that the high-frequency resistance of the grounds was much greater than we had estimated. These grounds were made with lines of iron wire laid in water. The substitution of copper wires removed this

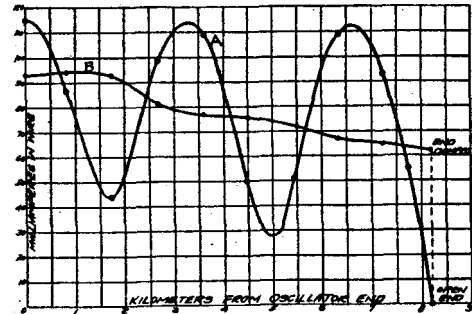

FIG. 9—OSCILLATOR TESTS ON RIVERHEAD ANTENNA. SINGLE UPPER WIRE,  $\lambda = 7500$ . A END OPEN. B END GROUNDED THROUGH 600 OHMS.

difficulty. The adjustment of resistance for unidirectional effects was now clean cut and in accord with the theory. A dead ground at the N. E. end gave as bad a stray ratio on the average as an open circuit.

EXPLANATION OF THE ACTION OF THE WAVE ANTENNA

The wave antenna in its simplest form consists of a horizontal wire of the order of a wave length long pointing towards the transmitting station, as pictured in Fig. 10.

When the signal wave reaches the end "A" an e. m. f. is induced in the horizontal antenna wire, due to the fact that the wave front is not perpendicular to the

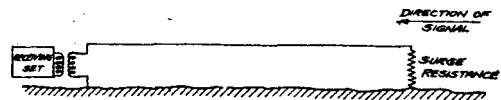

FIG. 10—SIMPLE WAVE ANTENNA

ground, but has a tilt forward of 1 deg. to 10 deg., depending on the wave length and character of ground. Thus, at the end A, a little wave starts to run down the antenna towards the receiving station, and if it travels with the same velocity as the radio wave in space, the space wave follows right along with it, supplying energy to it as it goes and building it up, until at the end B it has reached a magnitude many times that which it had at A. This is illustrated in Fig. 11 which shows a single wave at successive time intervals. If the velocity of the wave on the wire is not equal to the space

wave (velocity of light) interference effects develop, the wave on the wire building up for a certain distance and then decreasing in amplitude. The velocities on actual antennas, however, are nearly enough equal to that of light so that for considerable lengths the wave on the wire builds up as it would on a light velocity line.

A signal coming from the opposite direction to that which we have been considering, will build up a wave on the wire in a similar way, from a small value at B

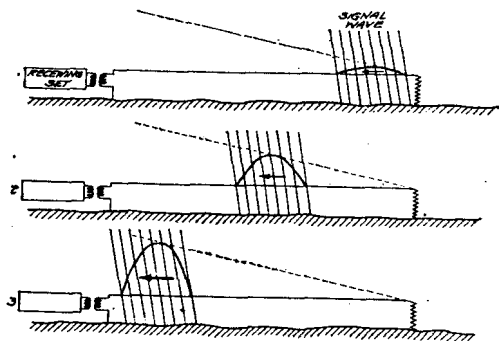

FIG. 11—BUILDING UP OF WAVE ON WIRE AS SPACE WAVE PROGRESSES

to a large value at A. If now the line were open or grounded at A, the wave would be reflected back over the antenna to the receiver end B, and would be heard. On the other hand, if we damp the end A in such a manner as to prevent reflections, the antenna becomes unidirectional. A non-inductive resistance, having the value  $R = \sqrt{L/C}$  ohms, where  $L$  and  $C$  are the inductance and capacity of the antenna per unit length, constitutes a practically perfect damper.

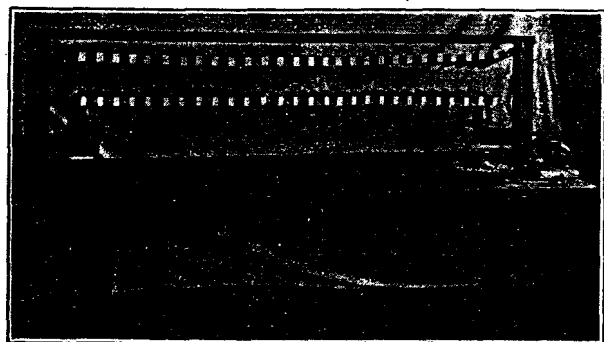

FIG. 12—MECHANICAL MODEL OF WAVE ANTENNA—STATIONARY VIEW

Many mechanical analogies will occur to the reader, such as the building up of water waves in the direction of the wind. An interesting experiment is to run over thin ice. If you run at just the speed of wave propagation of the ice surface you can build up a larger wave. If you run too slow or too fast little effect is produced. To demonstrate the manner of building up of waves on a wave antenna, Rice and Kellogg built the mechanical model shown in Figs. 12 to 17. The upper line represents the space wave and the lower line the wave on the wire. Each line consists of a series of wooden sticks

strung on a pair of small steel wires a half inch apart in the case of the lower line and an inch and a half apart in the upper line. The rockers of the upper line are loaded with lead. The inertia of the rocking stick is analogous to line inductance, while the elasticity of the connection between successive sticks is analogous to the capacity between the conductors of an electrical line. The velocity can be changed by varying the tension on the wires. The dashpots at the ends practically stop reflections. The upper line provides a means of imparting energy progressively to the different portions

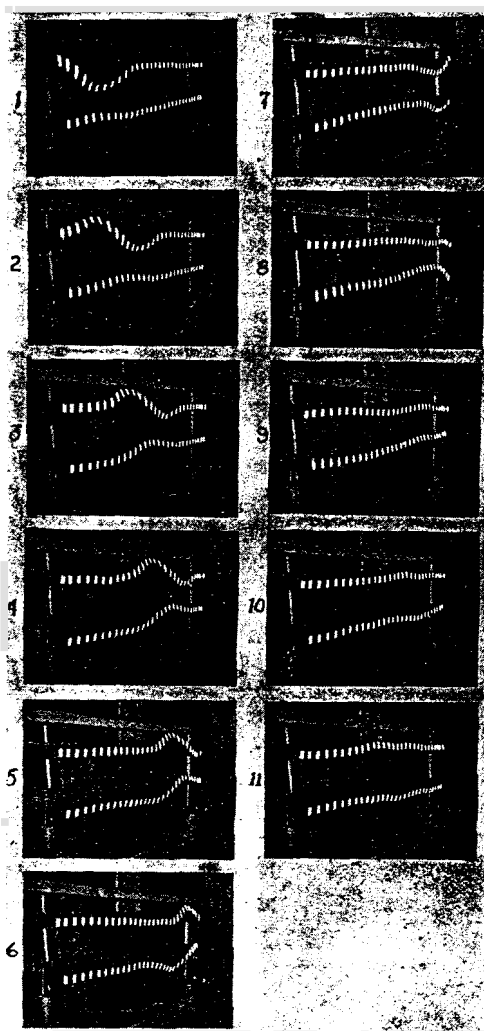

FIG. 13—MECHANICAL MODEL OF WAVE ANTENNA WITH END DAMPED

of the lower line, as a space wave imparts energy to the antenna line. A slight coupling between the two lines is supplied by light rubber bands stretched from short hooks on the upper sides of the lower sticks to corresponding hooks on the under side of the upper sticks. Waves are imparted to the upper line by moving one end by hand for an impulse or by a motor driven rocker for continuous waves.

Fig. 12 is a stationary view of the machine.

Fig. 13 shows a series of views taken with a moving picture camera, when an impulse is imparted to the

upper line. The growth of the wave on the lower line as it approaches the far end is readily seen. The wave on the lower line appears to pass off the end leaving the line practically stationary.

Fig. 14, compared with 13 shows the effect of removing the dashpot, thus permitting a free end reflection. We notice in these pictures a return wave which on reaching the near end, causes a movement of

line (antenna) as the waves progress from left to right. That the upper line carries practically pure traveling waves (i. e. has no return waves) is shown by the nearly uniform amplitude throughout its length.

Fig. 16 shows the effect of removing the dashpot at the right hand end of the lower line. Considerable movement at the extreme left end now appears, due to

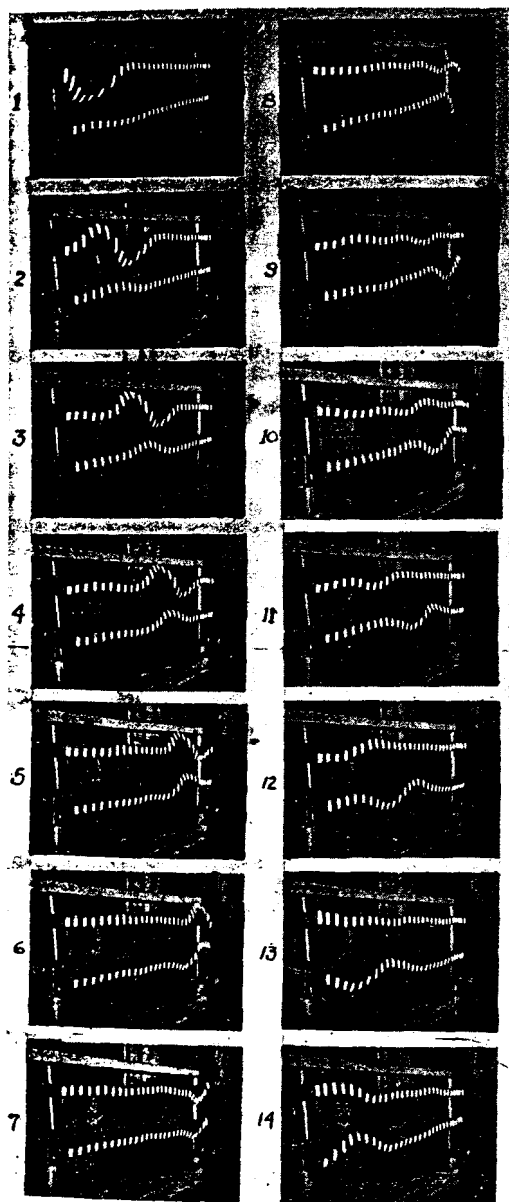

FIG. 13 MODEL OF WAVE ANTENNA WITH REFLECTION

the first rocker. This illustrates the loss of unidirectional properties if the end is not damped.

Time exposures, with continuous waves of constant amplitude supplied to the upper (space wave) line, bring out the amplitudes developed on various parts of the lower line, or the equivalent of current distribution in a wave antenna.

Fig. 15 shows the increase in amplitude on the lower

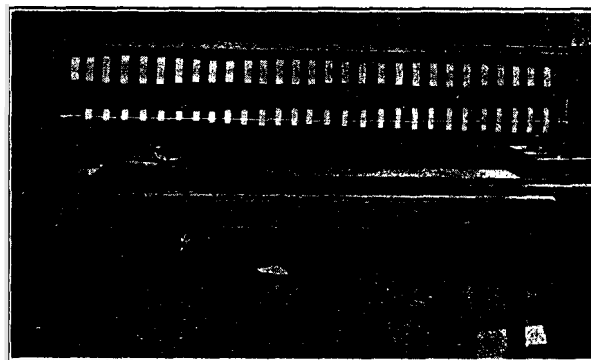

FIG. 15—MECHANICAL MODEL OF WAVE ANTENNA—FULL VELOCITY, BUILDING UP

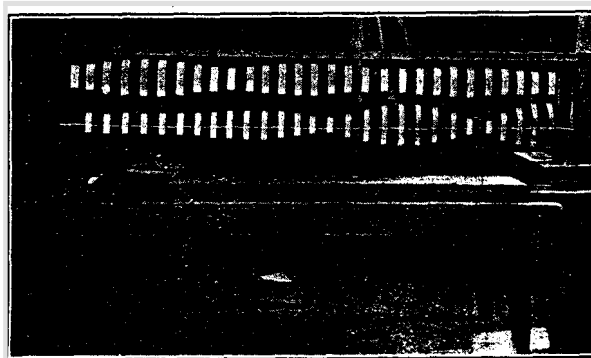

FIG. 16—MECHANICAL MODEL OF WAVE ANTENNA—FULL VELOCITY REFLECTION AT END

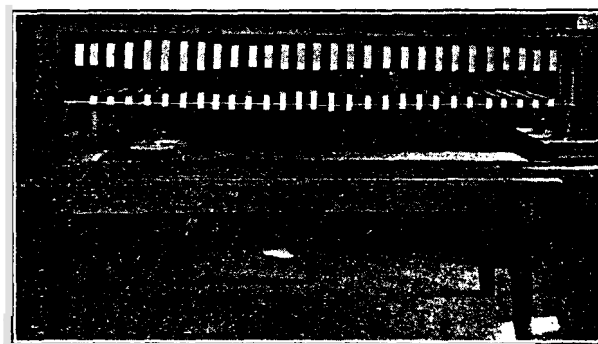

FIG. 17—MECHANICAL MODEL OF WAVE ANTENNA—SLOWED DOWN

the reflected wave. The forward wave (left to right) built up on the line, is very small near the left end, so we find the amplitude there nearly uniform, as would be expected with waves traveling in one direction only (right to left). On the other hand toward the right we see very clear standing wave effects, for here the for-

ward (left to right) wave has an amplitude more nearly equal to that of the return wave.

In Fig. 17 the right hand end is again damped, and the lower line has been slowed down by reducing the tension on the wires. This illustrates the building up and down of the waves on the antenna when its velocity is much below that of the wave in space.

REDUCTION TO PRACTICAL FORM

After the construction of the Riverhead antenna, considerable time was devoted to experiments of various kinds with the new antenna, tests and comparisons of different antenna arrangements, an oscillographic study of static, and tests of station apparatus.

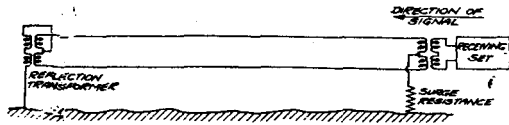

FIG. 18—ARRANGEMENT FOR LOCATING RECEIVING SET AT SAME END AS SURGE RESISTANCE

Messrs. P. Beverage, Rice, Kellogg, P. S. Carter, R. D. Green, and E. P. Lawsing participated. A number of practical developments were evolved in the course of this work. The "Reflection Transformer" Circuit. In order that the receiving set might be located at the same end of the line as the surge impedance, thereby facilitating adjustment, the arrangement shown in Fig. 18 was proposed by Kellogg. The two wires work in multiple as an antenna, but act as a balanced transmission line to bring the signal currents back from the southwest end. This scheme obviates the use of extra wires for the return transmission line and thus avoids the problem of preventing detrimental effects of nearby conductors.

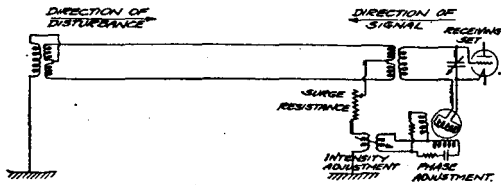

FIG. 19—FIRST BALANCING CIRCUIT EMPLOYED FOR OBTAINING ZERO RECEPTION FROM TEE BACK END

When the primary of the "reflection transformer" was opened the receiving set was quiet, showing that the transmission line although it was not transposed, was not introducing any undesirable electromotive forces. Thus a horizontal loop receives neither static or signal.

**Compensation for Back Wave.** Beverage showed that while the resistance could be adjusted to give a minimum for static while listening to European signals, still better stray ratios were obtained by combining with the signal currents brought in over the transmission line, a small amount of the currents flowing to ground at the northeast end of the antenna. This he accomplished

with a phase adjuster and intensity coupler of the type used by Mr. Alexanderson in the barrage receiver. The circuit arrangement is shown in Fig. 19.

The two long wave stations New Brunswick (13,600 meters) and Annapolis (16,900 meters) were of great assistance in making tests and adjustments. Either station could be entirely put out by using the phase and intensity adjustments of Fig. 19. It was found that when the adjustments were made for putting New Brunswick out, the stray ratio was best on the European stations whose wave lengths were near that of New Brunswick, and that when Annapolis was put out the adjustments were such as to give the best possible stray ratio for the longer wave European stations. In other words, the best stray ratio was obtained when the end conditions were adjusted to put out the image of the desired European station. If a light-velocity wave antenna is an exact number of half wave lengths long, the mathematical analysis shows that it is unidirectional provided the true surge impedance is connected between antenna and ground at the end nearest the transmitting station. This is illustrated in Fig. 29. Whether the true surge impedance is non-inductive or contains a capacity or inductive component will depend upon the

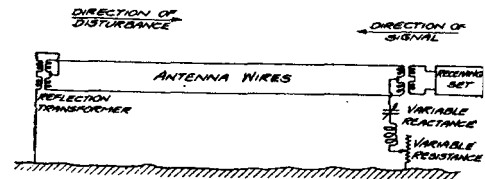

FIG. 20—METHOD OF BALANCING BACK END CURRENTS BY REFLECTIONS FROM DAMPED END

characteristics of antenna and ground at the frequency under consideration. Kellogg pointed out that since the antenna was not an exact number of half wave lengths long, the back wave effect would prevent the antenna from being unidirectional even though the true surge impedance had been used, and it was for this reason that Beverage found that balances were required to obtain the best stray ratio. Another method proposed by Kellogg of supplying this necessary compensation was to insert a circuit consisting of inductance, resistance, and capacity in series in the neutral at the end nearest the transmitting station, as shown in Fig. 20. By adjusting the resistance and varying the capacity through the point where it tuned out the reactance of the coil, a wave of any desired intensity and phase could be reflected down the antenna to exactly compensate for the back wave effect and thus render the antenna unidirectional.

If only one station is to be received the circuit shown in Fig. 20 is as satisfactory as any that the writers have found. For reception of long wave stations an antenna output transformer was used having a step-down ratio of 200 to 10 turns, and having a complete iron magnetic circuit of about 3/4 square inch cross section, made of

0.0015 enamelled sheet iron of the kind developed for the Alexanderson alternators. The secondary was connected in series with the first tuned circuit of the receiving set.

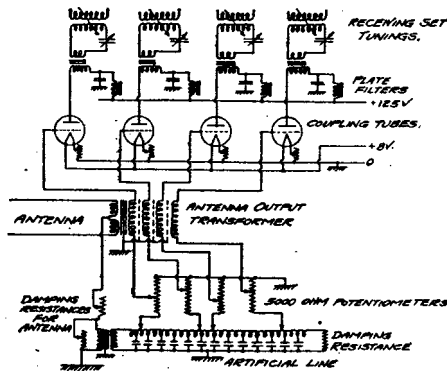

FIG. 21—MULTIPLEX RECEIVING SYSTEM

**Multiplex Reception.** - The simultaneous reception of a number of stations was one of the next objects of our work. If the surge impedance is set at the best value for a mean wave length, and no finer adjustment of the

The arrangement shown in Fig. 21 was worked out, and proved entirely satisfactory. Each coupling tube feeds a receiving set, and the antenna output transformer and artificial line, with its sliding contacts and potentiometers, serve to impress the desired potentials on the grids of the tubes. Since the load is negligible there is no reaction between the different sets. Grounded shields between the secondaries of the antenna output transformer prevent electrostatic reactions. The desired component of the currents or potentials in the ground circuit can be obtained in any desired phase by moving the sliding contact along the artificial line, and in the needed intensity by adjusting the potentiometer. The artificial line has a characteristic impedance of about 400-ohms and reflections are prevented by a resistance of about this value. This results in a phase adjustment which gives practically constant intensity. Five thousand ohms potentiometers are used, and these constitute so small a load on the artificial line that the adjustment of any one does not appreciably vary the potential distribution on the line. The artificial line, damped as it is at the far end, acts as a practically pure resistance in the antenna surge impedance circuit. By

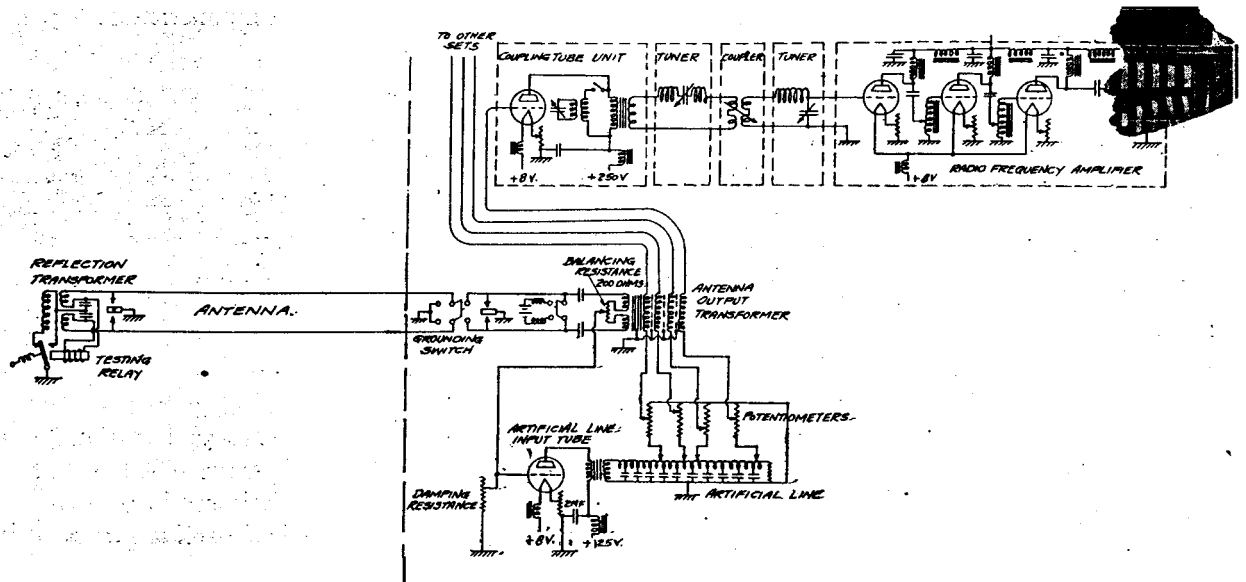

FIG. 22—WAVE ANTENNA CIRCUITS. PRESENT ARRANGEMENT

back-end compensation is attempted, then it is only necessary to provide more secondaries for the antenna output transformer, Fig. 20. In order that one set should not sap too much energy from another, transformers were designed with very slight reaction between the secondaries. Some data were taken of the best resistance and reactance in the ground circuit, as a function of wave length, and networks were figured out which would give the desired impedances at the wave lengths of the stations which it was most important to receive. This system of multiplexing, however, did not appeal to the writers as the most satisfactory solution of the problem. A system was wanted in which all the adjustments for each station to be received could be made without reacting on the adjustments for the others.

adjustment of the series and shunt resistance boxes the antenna damping resistance may be set at the best average value, leaving only a small residual to be "cleaned up" by the artificial line adjustments.

Fig. 22 is a more detailed diagram showing some changes which have been made since the original installation.

**Shielded Sets.** The aperiodic nature of the wave antenna and the success of the coupling tube multiplex system made it clear that there would be call for operating a number of receiving sets in the same building. The artificial line and antenna output transformer had been designed for operating four sets, but this was not necessarily the limit. In fact, later, when the new Riverhead station was laid out a total capacity of nine



receiving sets was planned, six of which are now in daily operation. The amplifiers, detectors, and tuners previously used in the receiving sets of the Radio Corporation were unshielded, and the practise had been, where two sets were in use in the same station, to keep them well separated and operate from separate batteries. To meet the new situation, a new line of apparatus was developed. Each piece of apparatus was in a metal lined box, the metal lining being grounded, and connections between the boxes were made through shielded cable. All tuned inductances consisted of astatic pairs of coils, of compact form, thus reducing chances of magnetic coupling. The radio amplifier was shielded between stages as well as externally. The amplifiers and detector have individual plate and filament filters in the supply lines. A two stage filter was introduced in the circuit between the detector and the audio amplifier in order to prevent radio frequency currents and potentials from getting into the audio circuits where they might cause back coupling or interference between sets. Low resistance telephones were used to minimize electrostatic coupling. These pre-

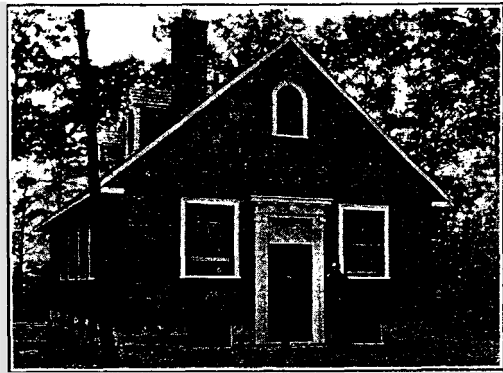

FIG. 23—RECEIVING STATION, RIVERHEAD, LONG ISLAND

cautions made it possible to operate the several sets in close proximity, and from the same plate and filament batteries, without any interference between sets, and to employ high radio and audio amplification without trouble from back coupling.

It was usual in receiving the high power European stations to develop a high-frequency potential of about 7 volts at the plate of the last tube in the radio amplifier, with a useful current of about 0.2 milliamperes. By connecting the output of the audio amplifier to a good telephone line, satisfactory tone signals were received and copied in New Ydrk City. Beverage arranged a rectifier for the audio frequency currents and operated a telegraph sounder, obtaining very satisfactory signals in this way when static was moderate or light. During the spring of 1921, considerable commercial traffic was received directly in New York in this manner, using the private telegraph wire which connected the Riverhead experimental station with the Broad St. Office of the Radio Corporation. One demonstration which aroused considerable interest consisted in putting Carnarvon's

signal on the telegraph line at Riverhead, and automatically repeating it at New York into the New Brunswick control line, so that the operators in the British station heard their own signal coming back on New Brunswick's wave.

When the success of the wave antenna had been demonstrated at Riverhead similar antennas were constructed at Chatham, Mass. and Belmar, N. J. where the Radio Corporation was already operating receiving stations. These new antennas gave satisfactory per-

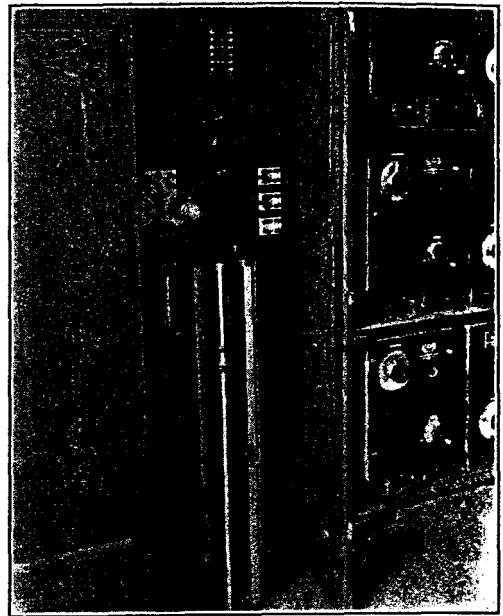

FIG. 24—ANTENNA PANEL, RIVERHEAD RECEIVING STATION



FIG. 25—SHIELDED RECEIVING SETS, RIVERHEAD, LONG ISLAND

formance in commercial service until the long wave traffic was finally concentrated in the new Riverhead station which the Radio Corporation constructed during the summer of 1921. Fig. 23 shows the present Riverhead Station. Fig. 24 shows an output transformer, artificial line and potentiometers, Fig. 25 shows shelves with two receiving sets. The building does not provide space for operators, since all signals are transferred to telephone lines and copied directly by operators

in the New York Office, or recorded automatically on tape.

### THEORY<sup>10</sup>

In order to work out a formula by which the directive properties of a wave antenna can be calculated, we shall consider space waves of some specified frequency, since the directive properties of a given antenna depend on the wave length to be received.

**Case 1. Signal Direction Parallel to Antenna, Zero Loss Antenna.** As the space wave travels along over the antenna, it induces an electromotive force successively in the different portions of the line. We may represent the electromotive force at the end A of the antenna shown in Fig. 26 by

$$e_s = E_0 \sin \omega t \quad (1)$$

volts per kilometer

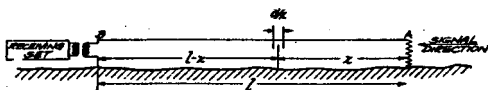

FIG. 26—MEASUREMENTS REFERRED TO IN DERIVATION OF EQUATIONS

Since it takes  $x/v$  seconds for the space wave traveling with a velocity  $v$  to reach the point X, the electromotive force  $e_x$  in the wire at the point X will be behind  $e_s$  in phase, or

$$e_x = E_0 \sin \omega (t - x/v) \quad (2)$$

Let us confine our attention for the present to the effects of the electromotive force induced in a small section of the wire  $dx$  kilometers in length, and situated  $x$  kilometers from the end A. Since  $e_s$  is expressed in volts per kilometer, the voltage induced in  $dx$  kilometers of wire will be

$$e, dx \text{ or } E_0 dx \sin \omega (t - x/v)$$

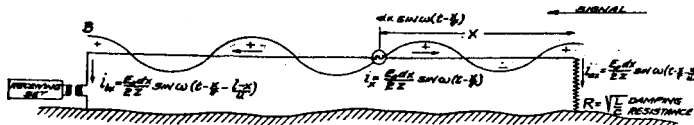

FIG. 27—CURRENTS RESULTING FROM VOLTAGE INDUCED IN SMALL SECTION OF ANTENNA

We may think of this little section of line as an alternator Fig. 27, supplying current to two transmission lines in series, one running to A and the other running to B. A line damped at the far end, so as to prevent reflection, shows an impedance  $Z = \sqrt{L/C}$  ohms at the input end, whatever the length of the line. We have here assumed such damping. If each line has an impedance  $Z$  ohms the alternator must work through an impedance  $2Z$  and will produce a current at X,

10. The Mathematical work of this paper is due to Kellogg.

11. This expression for Surge Impedance is strictly correct only for zero loss lines, but at radio frequencies it is a very close approximation for ordinary lines.

$$di_x = \frac{e_x dx}{2Z} = \frac{E_0 dx}{2Z} \sin \omega (t - x/v) \quad (3)$$

The alternator at X in forcing the current  $di_x$  through the line, gives rise to a train of waves moving toward B and another train of waves moving toward A. The resulting currents at the ends of the line  $di_{bx}$  and  $di_{ax}$  will be retarded in phase, as compared with  $di_x$ . If  $u$  is the velocity of wave propagation along the wire,

it will take  $\frac{l-x}{u}$  seconds for the forward waves to

reach B, and  $x/u$  seconds for the backward waves to reach A.

$$\text{Then } di_{bx} = \frac{E_0 dx}{2Z} \sin \omega \left( t - x/v - \frac{l-x}{u} \right) \quad (4)$$

$$di_{ax} = \frac{E_0 dx}{2Z} \sin \omega (t - x/v - x/u) \quad (5)$$

The total current at the end of the line is the sum of

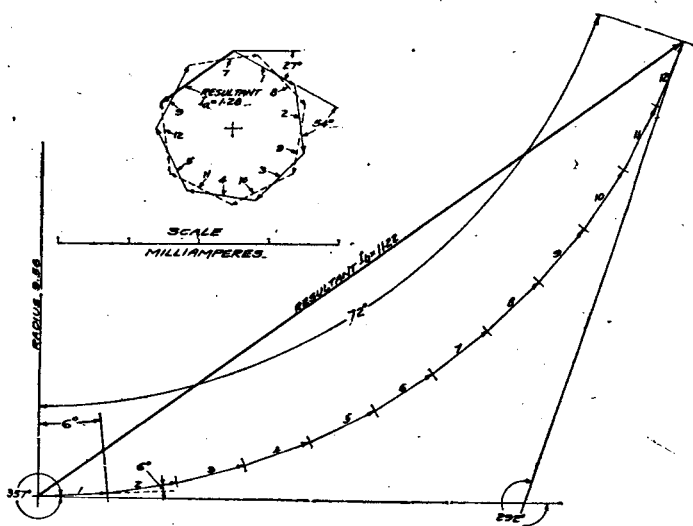

FIG. 28—DETERMINATION OF CURRENTS AT END OF WAVE ANTENNA BY VECTOR DIAGRAMS

the currents produced by each of the sections  $dx$  long in the line. We may perform the summation by integrating equation (4) or (5) between the limits  $x = 0$  and  $x = l$ , or by means of a vector diagram as shown in Fig. 28. The current at the end of the line  $di_{bx}$  or  $di_{ax}$ , resulting from the induced electromotive force in a section  $dx$  long, situated  $x$  kilometers from A, has a

maximum cyclic value or vector length  $\frac{E_0 dx}{2Z}$  and a

phase angle which varies with  $x$ , as shown in expression (4) and (5). Hence the summation will consist in

adding a series of vectors, each  $\frac{E_0 dx}{2Z}$  long, and each at

its proper phase angle. Taking the phase of  $e_s$  for reference, the angle of lag of  $di_{bx}$  as shown in (4) is

$$\psi_{bx} = \omega \left( \frac{x}{v} + \frac{l-x}{u} \right)$$

which may be written

$$\psi_{bx} = \frac{\omega}{u} \left\{ l - x \left( 1 - \frac{u}{v} \right) \right\} \quad (6)$$

and from (5) the angle of lag of  $d i_{ax}$  is

$$\psi_{ax} = \omega \left\{ x/v + x/u \right\} = \frac{\omega}{u} x \left( 1 + \frac{u}{v} \right) \quad (7)$$

any further change in the form of these expressions will be made for convenience.

The velocity  $u$  is equal to  $\frac{1}{\sqrt{LC}}$  where  $L$  and  $C$  are

series inductance and shunt capacity per unit length of line. Then  $\omega/u = \omega \sqrt{LC}$ , which will be recognized as the line wave length constant, for which the symbol  $\beta$  is frequently employed.

If we let  $n$  stand for the velocity ratio  $u/v$  and substitute  $\beta$  for  $\omega/u$  we get

$$\psi_{bx} = \beta \{ l - x (1 - n) \} \quad (8)$$

$$= \beta x (1 + n) \quad (9)$$

For the purpose of numerical calculation it is convenient to express  $\beta$  in terms of  $\lambda$  and  $n$  as follows:

$$\beta = \omega/u = \frac{2 \pi f}{n v} \text{ and since } \lambda = \frac{v}{f},$$

$$\beta = \frac{2 \pi}{n \lambda} \text{ radians per kilometer} \quad (10)$$

Distance (Km.).....	0.5	1.5	2.5	3.6	4.5	5.5	6.5	7.5	8.5	9.5	10.5	11.5
in radians.....	6.23	6.12	6.02	5.91	5.8	5.7	5.6	5.5	5.38	5.28	5.17	5.06
in degrees.....	357	351	345	339	333	327	321	315	309	303	297	292
in radians.....	0.47	1.41	2.35	3.29	4.23	5.16	6.10	7.04	8.0	8.93	9.87	10.80
in degrees.....	27	81	135	189	243	297	352	405	459	513	567	622

Let us illustrate the vector diagram method of summing up the currents by a numerical example. Assume the antenna length  $l$  to be 12 kilometers, its wave velocity  $u$  equal to 0.8 of that of light, and its impedance equal to 500 ohms, and a signal having a wave length of 15 kilometers and an intensity  $E_0 = 10$  millivolts per

kilometer. In the present case  $\beta = \frac{2 \pi}{n \lambda} =$

$$\frac{271}{15} = 0.522 \text{ radians per kilometer. Take } \beta l = 6.26 \text{ radians. (15)}$$

Let us take  $x$  as 1 kilometer, giving  $x$  the values 0.5, 1.5, 2.5, 3.5—11.5 kilometers. The corresponding phase angles, derived from expressions (8) and (9) are

$$\psi_{bx} = \beta \{ l - x (1 - n) \} = \frac{0.01 \times 1}{15} = 0.000667 \text{ radians}$$

at the front end of the antenna. The back end current  $I_b = 112.2$  microamperes and back end current  $I_r = 12.8$  microamperes.

This expression ignores line losses, but is a very close approximation in all cases with which we shall have to deal. The same value of the expressions  $Z = \sqrt{L/C}$  and  $\beta = \omega \sqrt{LC}$

These diagrams help us to see how we may write out an expression for the resultant currents. If we divide the line into a large number of very short sections the series of vectors form an arc of a circle instead of a polygon. The length of this arc is the length of one

vector  $\frac{E_0 dx}{2Z}$  multiplied by the number of sections

$\frac{l}{dx}$  which gives  $\frac{E_0 l}{2Z}$  If the vectors all lay on a

straight line  $\frac{E_0 l}{2Z}$  would be the length of the total cur-

rent vector. This condition is met at the end  $B$  when  $u = v$ . For any other line velocity, or for the current at the end  $A$ , the arc while of the same total length, will have a certain curvature, and the length of the chord subtending the arc, which is the resultant vector, will depend on the curvature. For a given length of arc the curvature is measured by the total angle, or the angle between the first and last vectors, corresponding to  $x = 0$  and  $x = l$  in (8) or (9). Thus in the case of the  $I_b$  vector addition we put  $x = 0$  and  $x = l$  in equation (8) to obtain the initial and final directions of the arc, which gives

$$\psi_{b0} = \beta l$$

and

$$\psi_{bl} = \beta l n$$

The difference or total angle through which the arc turns is

$$\psi_{b0} - \psi_{bl} = \beta l (1 - n)$$

The radius of curvature  $r$  is given by  $r = \frac{\text{arc}}{\text{angle}}$  or

$$r = \frac{\frac{E_0 l}{2Z}}{\beta l (1 - n)} = \frac{E_0 l}{2Z \beta l (1 - n)}$$

The length of the chord which is the vector of the resultant current  $I_b$  is given by

$$\text{chord} = 2 r \sin \frac{1}{2} (\text{angle}) \text{ or } I_b = 2 \frac{E_0 l}{2Z \beta l (1 - n)} \sin \frac{1}{2} \beta l (1 - n)$$

Cancelling the  $2l$  in the numerator and denominator gives

$$I_b = \frac{E_0}{Z \beta (1 - n)} \sin \frac{1}{2} \beta l (1 - n) \quad (11)$$

By the same process using equation (9) we get

$$I_r = \frac{E_0}{Z \beta (1 + n)} \sin \frac{1}{2} \beta l (1 + n) \quad (12)$$

13. A formula which correctly showed the end currents as functions of the antenna length and the velocity ratio, was first worked out during the early Eastport work by Mr. P. S. Carter.

These expressions give  $I_b = 112$  microamperes and  $I_a = 12.2$  microamperes for the problem worked graphically in Fig. 28. The difference between these values and those found from the graphical solution is due to the inaccuracy involved in the graphical method using so few sections.

It will be noticed that if the sign of  $n$  is changed in (11) we get (12). We may consider the sign of the signal velocity  $v$ , to be negative when the signal comes from the opposite direction. Since  $n$  is defined as  $u/v$ , this would give  $n$  a negative sign. Therefore, there is only one formula required, and to find the back end current  $I_b$  we consider the signal direction to be reversed.

We showed that if  $u = v$  the arc is a straight line and  $I = \frac{E_0 l}{2Z}$ . If we set  $n = 1$  in (11), we get the indeterminate form  $0/0$ , and to evaluate the expression we make use of the relation that  $\frac{\sin a'}{a}$  approaches 1 as  $a$  approaches 0, where the angle  $a$  is expressed in radians. Thus in (11)

$$\frac{\sin \frac{1}{2} \beta l (1-n)}{\beta (1-n)}$$

which may be written

$$\frac{\frac{1}{2} l \sin \frac{1}{2} \beta l (1-n)}{\frac{1}{2} \beta l (1-n)}$$

approaches  $\frac{1}{2} l$  as  $\frac{1}{2} \beta l (1-n)$  approaches 0, and expression (11) takes the value

$$I_b = E_0/Z \times \frac{1}{2} l \text{ or } \frac{E_0 l}{2Z}$$

Hence when  $u = v$

$$I_b = \frac{E_0 l}{2Z} \tag{11a}$$

Figure 29<sup>14</sup> shows the receiver end and back end currents calculated by equations (11a) and (12) for antennas of various lengths, assuming

- $u = v = 3 \times 10^5$  kilometers per second
- $\lambda = 12$  kilometers
- $E_0 = 0.010$  volts per kilometers
- $Z = 500$  ohms

These curves bring out the unidirectional properties of the wave antenna.

**Case II. Signal at an Angle to Antenna, Zero Loss Antenna.** So far we have considered only signal waves traveling in the direction of the antenna. To calculate the directive properties of the antenna, we must find the

<sup>14</sup> This figure is practically a reproduction of a curve plotted by Mr. P. S. Carter, based on his calculations previously mentioned.

effect of a signal of the same wave length and intensity coming at an angle to the antenna. In the first place there will be a difference in the electromotive force  $E_0$  induced in a unit length of wire. In Fig. 30A, we imagine ourselves looking down at two horizontal wires, each of unit length, situated in the midst of a signal wave whose magnetic lines are shown as dotted lines in the figure. Only the magnetic lines in a very thin layer

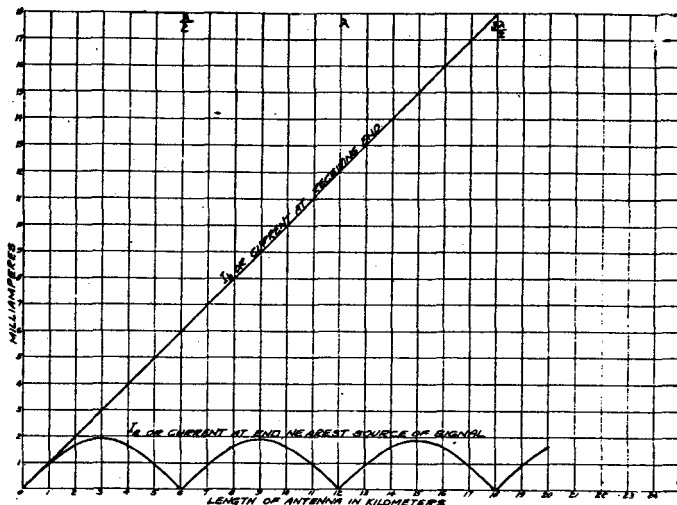

FIG. 29—RELATIVE CURRENTS AT THE TWO ENDS OF A WAVE ANTENNA

immediately over the plane of the wires are shown. These magnetic lines have a horizontal movement indicated by the arrow, and a downward movement resulting from the forward tilt of the wave front. The horizontal movement causes no cutting of the conductor. Owing to the downward movement, the wires will be cut by all of the lines which cross them in the figure. The numbers of magnetic lines which cross wires No. 1 and

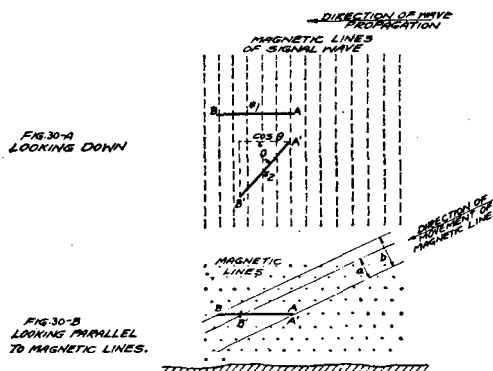

FIG. 30—EFFECT OF ANTENNA ANGLE ON INDUCED ELECTROMOTIVE FORCE PER UNIT LENGTH

No. 2 are in the ratio 1 to  $\cos \theta$ , and the induced electromotive force per unit length will be in the same ratio. Another point of view is illustrated in Fig. 30B, in which we imagine ourselves as looking at the ends of the magnetic lines, which now appear as dots. Here the same two wires are shown, and the actual direction of motion of the magnetic lines is indicated. Only

those lines within the region *a* will cut wire No. 2 which appears in this projection as *A' - B'*, while all those in region *b* will cut No. 1, and the ratio of *a* to *b* is again  $\cos \theta$ . We shall therefore multiply by  $\cos \theta$  to take account of the difference in induced electromotive force. That is to say if a signal coming in the direction of the antenna induces  $E_0$  volts per kilometer, a signal of the same intensity coming from an angle  $\theta$  to the antenna will induce  $E_0 \cos \theta$  volts per kilometer.

The angle which the signal direction makes with the antenna also effects the time required for the wave front to pass over the antenna, and therefore affects the relative phases of the electromotive forces induced in the different parts of the antenna. From the time the maximum electromotive force occurs at *A* to the time the same thing occurs at *X* the wave has only to travel a distance  $x \cos \theta$  as indicated in Fig. 31, and this will

require  $\frac{x \cos \theta}{v}$  seconds, where *v* is the velocity of the

Signal wave. If the induced electromotive force at *A* is  $e_a = (E_0 \cos \theta) \sin \omega t$  then at *X* it will be

$$e_x = (E_0 \cos \theta) \sin \omega \left( t - \frac{x \cos \theta}{v} \right) \quad (13)$$

Comparing (13) with (2) we see that we now have the factor  $\frac{v}{\cos \theta}$  where we had simply *v*, and where we had

$E_0$  we now have  $E_0 \cos \theta$ . Replacing *v* by  $\frac{v}{\cos \theta}$  mean

changing *u/v* or *n* to  $n \cos \theta$ . Making these changes in (11) gives us, for the current due to a signal coming from a direction  $\theta$  from the antenna.

$$I_\theta = \frac{E_0 \cos \theta}{Z \beta (1 - n \cos \theta)} \sin \frac{1}{2} \beta l (1 - n \cos \theta) \quad (14)$$

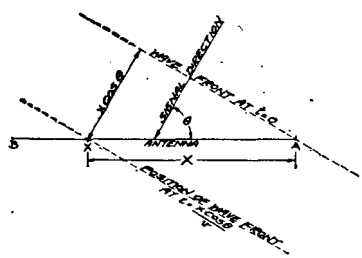

FIG. 31—EFFECT OF SIGNAL ANGLE ON TIME REQUIRED FOR WAVE TO TRAVERSE ANTENNA

If the signal is traveling in the direction of the antenna,  $\theta = 0$ , and  $\cos \theta = 1$ , and (14) become the same as (11). If the signal is from the opposite direction  $\theta = 180$  deg.,  $\cos \theta = -1$  and (14) becomes the same as (12).

Let us apply formula (14) to the calculation of the directive curve of the antenna whose currents for  $\theta = 0$  and  $\theta = 180$  deg. were determined in Fig. 28. The calculations are shown in Table I. Column IX,

multiplied by  $E_0/Z$  would give the currents corresponding to the value assumed for  $E_0$ . To show directive properties, however, it is more satisfactory to give the current for any direction in terms of its ratio to the current which the same signal would produce if it came from the direction for which the antenna gives maximum reception. Thus column X gives the relative current strengths as found by dividing all the figures of column IX by the largest figure in the column which is 5.6 and corresponds to  $\theta = 0$ . Fig. 32 shows the directive

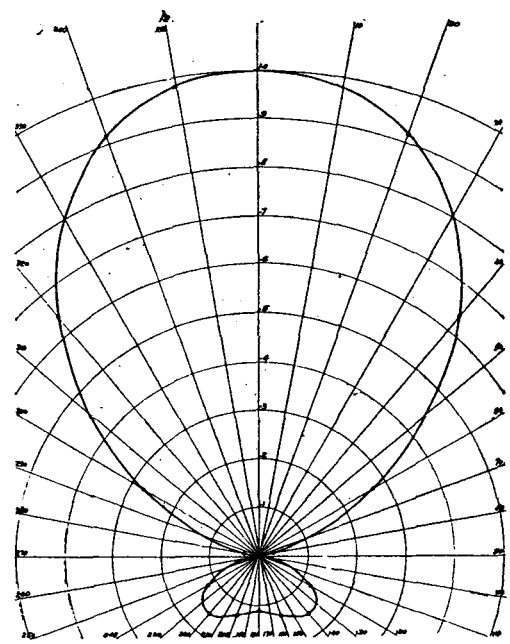

FIG. 32—DIRECTIVE CURVE OF WAVE ANTENNA.  $\lambda = 15$  KM.  $l = 12$  KM.,  $\alpha = .0$ ,  $u = 0.8v$

curve of the antenna, obtained by plotting the relative currents as shown in column X radially at the corresponding angles.

**Case III. Line Losses Considered.** The factor *line attenuation* has so far been left out of account in order to simplify the problem. We assumed that the current at the end of the line, resulting from a wave which started at some point *X*, had the same strength as at *X*, although of different phase.

In the case of bare copper wire on poles, the errors due to ignoring line losses are not in general large enough to give misleading results. There are many instances however in which line losses are high or the antenna unusually long, where these effects cannot be neglected.

When there are no reflections to cause standing wave effects, the decrease in current strength as we go farther from the source is expressed by the relation  $I_x = I_0 e^{-\alpha x}$ , in which  $I_0$  is the current strength at the source,  $I_x$  the current at a distance *x* from the source, and  $\alpha$  is the "attenuation constant" of the line. A value of 0.05 per kilometer for  $\alpha$ , means that the current decreases about 5 per cent with every kilometer which the wave travels.

In deriving equations (4) and (5), we regarded the

TABLE I  
DIRECTIVE CURVE OF WAVE ANTENNA ZERO ATTENUATION

$$I = \frac{E_0 \cos \theta}{Z \frac{\omega}{u} (1 - u \cos \theta)} \sin \frac{1}{2} \frac{e}{u} l \left( 1 - \frac{u \cos \theta}{v} \right)$$

$$= \frac{E_0 \cos \theta}{Z 0.524 (1 - 0.8 \cos \theta)} \sin 180 \text{ deg. } (1 - 0.8 \cos \theta)$$

l = 12 km.  
A = 15 km.  
u = 0.80.  
a = 0

I	II	III	IV	V	VI	VII	VIII	IX	X
$\theta$ deg. Signal Angle	$\cos \theta$	$0.8 \cos \theta$	$1 - 0.8 \cos \theta$	$0.524 (1 - 0.8 \cos \theta)$	$180 \text{ deg. } (1 - 0.8 \cos \theta)$	$\sin 180 \text{ deg. } (1 - 0.8 \cos \theta)$	VII + V	VIII X $\cos \theta$	Relative Current IX + 5.6
0	1.00	0.8	0.2	0.105	36	0.588	5.6	5.6	1.00
20	0.94	0.752	0.248	0.13	44.8	0.704	5.4	5.08	0.91
40	0.766	0.612	0.388	0.203	70	0.94	4.62	3.54	0.63
60	0.50	0.40	0.60	0.314	108	0.951	3.02	1.51	0.27
80	0.174	0.139	0.861	0.450	155	0.423	0.94	0.164	0.03
90	0	0	1.00	0.524	180	0	0	0	0
100	-0.174	-0.139	1.139	0.596	205	-0.423	-0.71	0.124	0.022
120	-0.50	-0.40	1.40	0.734	252	-0.951	-1.29	0.645	0.115
140	-0.766	-0.612	1.612	0.845	290	-0.94	-1.11	0.85	0.152
160	-0.94	-0.752	1.752	0.918	315	-0.707	-0.77	0.724	0.129
180	-1.00	-0.80	1.80	0.945	324	-0.588	-0.622	0.622	0.111

TABLE II  
DIRECTIVE CURVE OF WAVE ANTENNA

$$\text{Vector } I_0 = \frac{E_0 \cos \theta \epsilon}{2 Z \left[ \alpha + j \frac{2 \pi}{n \lambda} (1 - n \cos \theta) \right]} \left\{ 1 - \epsilon \frac{-j \frac{2 \pi \cos \theta}{\lambda} l \left[ \alpha + j \frac{2 \pi}{n \lambda} (1 - n \cos \theta) \right] l}{1 - \epsilon} \right\}$$

$\lambda = 12 \text{ km.}$   
 $l = 12 \text{ km.}$   
 $u = 0.8 \text{ v.}$   
 $\alpha = 0.05$   
 $\epsilon = \alpha l = .55$

Arranging Formula for Calculation of Magnitude and Substituting Numerical Values of Constants, we have

$$\text{Magnitude } I = \frac{E_0 \cos \theta}{2.2 \sqrt{(0.05)^2 + (0.654)^2 (1 - 0.8 \cos \theta)^2}} \left\{ \begin{array}{l} \text{Vector Difference of 1.0 and 0.55} \\ \text{at Angle } 450 \text{ deg. } (1 - 0.8 \cos \theta) \end{array} \right\}$$

I	II	III	IV	V	VI	VII	VIII	IX	X	XI
$\theta$ Signal Angle	$\cos \theta$	$0.8 \cos \theta$	$1 - 0.8 \cos \theta$	$0.65 (1 - 0.8 \cos \theta)$	$\sqrt{(0.05)^2 + (0.654)^2 (1 - 0.8 \cos \theta)^2}$	$450 \text{ deg. } (1 - 0.8 \cos \theta)$	(Vector Difference) Graphical Solution	VIII + VI	IX X $\cos \theta$	Relative Current X + 8.14
0	1.00	0.80	0.2	0.131	0.140	90	1.14	8.14	8.14	1.0
20	0.940	0.752	0.248	0.162	0.169	112	1.31	7.75	7.3	0.896
40	0.760	0.613	0.387	0.253	0.258	174	1.55	6.0	4.6	0.565
60	0.50	0.40	0.6	0.393	0.396	270	1.14	2.89	1.45	0.178
80	0.1736	0.139	0.861	0.564	0.566	388	0.58	1.02	0.177	0.022
100	-0.1736	-0.139	1.139	0.744	0.745	513	1.51	2.03	0.35	0.0431
120	-0.50	-0.40	1.40	0.916	0.916	630	1.14	1.25	0.62	0.0762
140	-0.766	-0.613	1.613	1.055	1.055	726	0.45	0.427	0.326	0.040
160	-0.94	-0.752	1.752	1.146	1.146	789	0.96	0.838	0.78	0.0958
180	-1.00	-0.80	1.80	1.18	1.18	810	1.14	0.97	0.97	0.119

point  $X$  in Fig. 26 as the source of waves on the antenna. We considered the current  $d i_{ax}$  and  $d i_{bx}$  at the ends of the line to have the same strength as the current  $d i_x$  at  $x$ , since we were treating the case of a zero loss line. We now wish to consider a line on which there is attenuation, so the current  $d i_{bx}$  at the end  $B$ , which is  $(l - x)$  kilometers from the source, will be weaker than the current  $d i_x$  at  $X$ , in the ratio  $\epsilon^{-\alpha(l-x)}$ , and the current  $d i_{ax}$  at the end  $A$ , which is  $x$  kilometers from the source, will be weaker in the ratio  $\epsilon^{-\alpha x}$ . The phase relations as before are those corresponding the time differences

$\frac{l-x}{u}$  seconds and  $\frac{x}{u}$  seconds required for waves to travel from  $X$  to  $B$  and  $X$  to  $A$  respectively. The

current at  $X$  is  $d i_x = \frac{e dx}{2Z}$ , or substituting the value

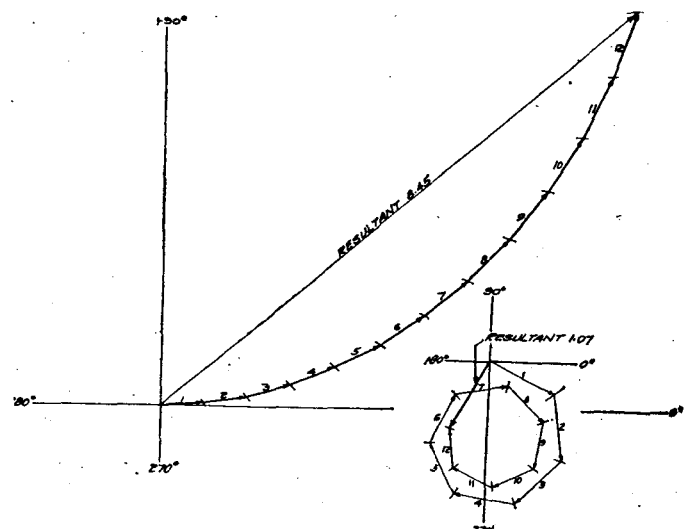

FIG. 33—DETERMINATION OF END CURRENTS FOR LINE WITH ATTENUATION

of  $e$ , given in (13)

$$d i_x = \frac{E_0 dx \cos \theta}{2Z} \sin \omega \left( t - \frac{x}{v} \right)$$

The current at  $B$  will be

$$d i_{bx} = \frac{E_0 dx \cos \theta}{2Z} \epsilon^{-\alpha(l-x)} \sin \omega \left( t - \frac{x}{v} - \frac{l-x}{u} \right) \quad (15)$$

and the current at  $A$  will be

$$d i_{ax} = \frac{E_0 dx \cos \theta}{2Z} \epsilon^{-\alpha x} \sin \omega \left( t - \frac{x}{v} - \frac{x}{u} \right) \quad (16)$$

The total end currents may be found by dividing the line into sections and drawing a series of vectors which present the end currents resulting from the induced electromotive forces in the successive sections, as was done in Fig. 28. In the present case the vectors will differ progressively in length as well as in phase. Fig. 33 shows diagrams for finding the end currents for a line in the same direction parallel to the antenna. The conditions

of the problem are the same as in the case of Fig. 28 except that for Fig. 33 an attenuation of 0.05 per kilometer is assumed. The corresponding vectors in the two figures have the same phase angles, but in Fig. 33 the vectors form a spiral instead of a circular arc.

The total end currents can be found by integrating equations (15) and (16) in their present form, but the work is simplified if we make use of vector notation.

In what follows, the symbols in bold faced type, such as  $\mathbf{E}$  or  $\mathbf{I}$  stand for vector quantities of the form  $a + jb$ , or its equivalent. For reference a summary is appended showing typical operations with vector quantities.

The induced volts per kilometer,  $\mathbf{E}_a = E_0 \cos \theta$  at the end  $A$  of the antenna in Fig. 26, will be taken as the reference vector and the phase angle of any current or voltage means its angle of lead or lag with respect to  $\mathbf{E}_a$ .

The induced voltage per kilometer,  $\mathbf{E}_x$  at the point  $X$  is of the same intensity as  $\mathbf{E}_a$  but lags behind  $\mathbf{E}_a$  by

$\omega \frac{x \cos \theta}{v}$  radians. Therefore the vector of  $\mathbf{E}_x$  is of the

same length as that of  $\mathbf{E}_a$  but is rotated backward, or

clockwise  $\omega \frac{x \cos \theta}{v}$  radians with respect to  $\mathbf{E}_a$ . This

backward rotation is accomplished by multiplying by

$\epsilon^{-j \omega \frac{x \cos \theta}{v}}$ , so that

$$\mathbf{E}_x = \mathbf{E}_a \epsilon^{-j \omega \frac{x \cos \theta}{v}} = (E_0 \cos \theta) \epsilon^{-j \omega \frac{x \cos \theta}{v}} \quad (17)$$

The voltage induced in  $dx$  kilometers of wire at  $X$  is  $\mathbf{E}_x dx$ , and this, acting through an impedance of  $2Z$  ohms produces a current at  $X$  of

$$d i_x = \frac{\mathbf{E}_x dx}{2Z} = \frac{E_0 dx \cos \theta}{2Z} \epsilon^{-j \omega \frac{x \cos \theta}{v}} \quad (18)$$

The waves on the wire must travel  $(l - x)$  kilometers from  $X$  to reach the end  $B$  of the antenna. Therefore compared with the current  $d i_x$  at  $X$ , the current  $d i_{bx}$  at  $B$ , is smaller in the ratio  $\epsilon^{-\alpha(l-x)}$  and retarded

in phase by the angle  $\omega \frac{l-x}{u}$  radians. Hence

$$d i_{bx} = d i_x \epsilon^{-\alpha(l-x)} \epsilon^{-j \frac{\omega}{u} (l-x)}$$

Combining exponents and substituting  $\beta$  for  $\omega/u$  we have

$$d i_{bx} = d i_x \epsilon^{-(\alpha + j\beta)(l-x)} \quad (19)$$

Substituting in this the value of  $d i_x$ , shown in (18) we have

$$d i_{bx} = \left\{ \frac{E_0 dx \cos \theta}{2Z} \epsilon^{-j \omega \frac{x \cos \theta}{v}} \right\} \epsilon^{-(\alpha + j\beta)(l-x)}$$

Combining exponents and collecting the  $x$  terms gives

$$d i_{bx} = \frac{E_0 dx \cos \theta}{2Z} \epsilon^{-\left\{ (\alpha + j\beta)l + (\alpha + j\beta - j \frac{\omega \cos \theta}{v})x \right\}} \quad (20)$$

The waves from  $X$  to  $A$  travel  $x$  kilometers on the wire, and are reduced in intensity in the ratio  $e^{-\alpha x}$  and retarded in phase by  $\omega x/v$  or  $\beta x$  radians. Therefore

$$\begin{aligned} d i_{ax} &= d i_x e^{-\alpha x} e^{-j\beta x} \\ &= d i_x e^{-(\alpha + j\beta)x} \\ &= \left\{ \frac{E_0 dx \cos \theta}{2Z} e^{-j\omega x (\cos \theta)/v} \right\} e^{-(\alpha + j\beta)x} \\ &= \frac{E_0 dx \cos \theta}{2Z} e^{-(\alpha + j\beta + j\omega x (\cos \theta)/v)} \quad (21) \end{aligned}$$

The total current  $I_b$  is the sum of all the currents  $d i_{bx}$ , corresponding to all values of  $X$ , or in other words we integrate the expression (20) for  $d i_{bx}$  between the limits  $x = 0$  and  $x = l$ .

$$I_b = \frac{E_0 \cos \theta}{2Z} e^{-(\alpha + j\beta)l} \int_{x=0}^{x=l} e^{(\alpha + j\beta - j\omega x (\cos \theta)/v)} dx$$

Performing the integration and substituting the limits gives

$$I_b = \frac{E_0 \cos \theta e^{-(\alpha + j\beta)l}}{2Z} \left\{ \frac{e^{(\alpha + j\beta - j\omega l (\cos \theta)/v)} - 1}{\alpha + j\beta - j\omega \frac{\cos \theta}{v}} \right\}$$

This expression gives the value of  $I_b$ , but it is more convenient for calculation if several changes are made in its form.

Putting  $e^{-(\alpha + j\beta)l}$  inside the parenthesis gives

$$I_b = \frac{E_0 \cos \theta \left\{ e^{-j\omega l (\cos \theta)/v} - e^{-(\alpha + j\beta)l} \right\}}{2Z \left( \alpha + j\beta - j\omega \frac{\cos \theta}{v} \right)}$$

Taking  $e^{-j\omega l (\cos \theta)/v}$  out of the parenthesis gives

$$I_b = \frac{E_0 \cos \theta e^{-j\omega l (\cos \theta)/v}}{2Z} \left\{ \frac{1 - e^{-(\alpha + j\beta - j\omega l (\cos \theta)/v)}}{\alpha + j\beta - j\omega \frac{\cos \theta}{v}} \right\}$$

Since  $\omega/v = \frac{wn}{\lambda} = \beta n$ , we may substitute

$j\beta(1 - n \cos \theta)$  for  $j\beta - j\omega \frac{\cos \theta}{v}$ , giving

$$I_b = \frac{E_0 \cos \theta e^{-j\omega l (\cos \theta)/v}}{2Z} \left\{ \frac{1 - e^{-(\alpha + j\beta(1 - n \cos \theta)l)}}{\alpha + j\beta(1 - n \cos \theta)} \right\} \quad (22)$$

A more satisfactory form of the equation for purposes of calculation is obtained by separating the attenuation and phase angle factors in the expression

$e^{-[\alpha + j\beta(1 - n \cos \theta)]l}$  and substituting  $\frac{2\pi}{\lambda}$  for  $\omega/v$

and  $\frac{2\pi}{n\lambda}$  for  $\beta$

This gives

$$I_b = \frac{E_0 \cos \theta e^{-j(2\pi l/\lambda) \cos \theta} \left\{ 1 - e^{-\alpha l} e^{-j \frac{2\pi l}{n\lambda} (1 - n \cos \theta)} \right\}}{2Z \left[ \alpha + j \frac{2\pi}{n\lambda} (1 - n \cos \theta) \right]} \quad (22a)$$

This is the complete expression for the current at the end  $B$  farthest from the signal source.

The total current at  $A$  is found similarly by integrating expression (21) for  $d i_{ax}$  between the limits  $x = 0$ , and  $x = l$

$$\begin{aligned} I_a &= \frac{E_0 \cos \theta}{2Z} \int_{x=0}^{x=l} e^{-(\alpha + j\beta + j\omega x (\cos \theta)/v)} dx \\ &= - \frac{E_0 \cos \theta \left\{ e^{-[\alpha + j\beta + j\omega l (\cos \theta)/v]} - 1 \right\}}{2Z \left[ \alpha + j\beta + j \frac{\omega \cos \theta}{v} \right]} \end{aligned}$$

Substituting  $j\beta(1 + n \cos \theta)$  for  $j\beta + j\omega \frac{\cos \theta}{v}$  and putting the  $-$  sign in the parenthesis, we have

$$I_a = \frac{E_0 \cos \theta \left\{ 1 - e^{-[\alpha + j\beta(1 + n \cos \theta)]l} \right\}}{2Z [\alpha + j\beta(1 + n \cos \theta)]} \quad (23)$$

or

$$I_a = \frac{E_0 \cos \theta \left\{ 1 - e^{-\alpha l} e^{-j \frac{2\pi}{n\lambda} l (1 + n \cos \theta)} \right\}}{2Z \left[ \alpha + j \frac{2\pi}{n\lambda} (1 + n \cos \theta) \right]} \quad (23a)$$

*Discussion of Equations.* Equations (22) and (23) give the currents at the two ends of the antenna in their relative magnitude and phase relations with respect to the induced voltage per kilometer  $E_a$ , at the end  $A$  of the antenna. The assumptions throughout are that the antenna is straight and uniform and free from reflections at the ends, and that the signal wave causes no other electromotive forces in the circuit than that in the horizontal wire. The assumption that the induced electromotive force per unit length of conductor is the same in all parts of the antenna, and is independent of the amplitude of the wave on the wire, means that the reduction in intensity of the space wave by divergence or ground absorption has been neglected, and that no saturation effect has been considered. The absorption and divergence of the space wave may be estimated with fair approximation, and in most cases with antennas of moderate length, will be found to be negligible. No evidence of saturation has so far come to the writers' attention. In cases where the antenna has exceeded the length which gave maximum signal, the limit to the amplitude of the waves on the wire, has been set by the velocity difference or the line losses.

It will be noticed that (22) is the same as (23) except that the algebraic sign before the term  $\cos \theta$  is reversed, and the factor  $e^{-j\omega l (\cos \theta)/v}$  appears in the numerator of (22). The latter term has no effect on magnitude



it effects the phase. If we should calculate the current at the end nearest the signal source by using formula (22) and assuming the signal to come from the opposite direction, or in other words take  $\theta$  as 180 deg. instead of 0 deg., we would get the same numerical value for the current as though we had used equation (3), but the phase angle would be different because in (3) the phase is expressed with reference to the voltage induced by the signal at the end nearest the source of signal, whereas in using (22) and reversing  $\theta$  to find the "back end" current, we refer the phase to that of the signal voltage at the end farthest from the signal source. We are concerned with the question of phase only when currents from two or more sources are to be combined. For example, in calculating the effects of reflections or of voltages induced in the end verticals, it would be necessary to know the phase relations of the currents which are combined. Or when in order to put a disturbance coming from a certain direction, we introduce in the receiving circuit a neutralizing current from another source, it is necessary to take account of the phases of the currents.

In making calculations of this kind we must watch the algebraic sign as well as the phase of the vector, and the following point should be kept in mind. An electro-motive force is taken as positive if it acts in the direction to *B* in Fig. 26, and a current is positive in this direction. Therefore, if we should find that the vectors for the back end and receiver end currents as figured by equations (23) and (22) point in the same direction, it would mean that the current at *A* is flowing from ground antenna at the instant that the current at *B* is flowing from antenna to ground.

For figuring the simple directive curve of a wave antenna which does not call for determining the phase of the end currents, we may work entirely with equation (2) omitting the factor  $e^{-j\omega l (\cos \theta)/v}$ . The expression in the bracket is a vector difference and may be evaluated graphically or by use of the familiar formula for the third side of a triangle when two sides and the angle between them are given. We have two vectors, one having a length 1, and the other having a length  $e^{-\alpha l}$ , and the angle between them is  $\beta (1 - n \cos \theta) l$

radians or  $\frac{360l}{n\lambda} (1 - n \cos \theta)$  degrees. The vector difference is

$$\sqrt{1 + (\epsilon^{-\alpha l})^2 - 2 \epsilon^{-\alpha l} \cos \frac{360l}{n\lambda} (1 - n \cos \theta)}$$
 The expression  $\alpha + j \beta (1 - n \cos \theta)$  in the denominator must be given in terms of its vector length  $\alpha^2 + \beta^2 (1 - n \cos \theta)^2$ . in order to calculate the current. Therefore, if the phase of the end current, relative to current or voltage in other parts of the antenna, is not sought, but only the magnitude of the current, we may use the following formula, which is obtained by making the changes just mentioned in

$$I_B = \frac{E_0 \cos \theta \sqrt{1 + (\epsilon^{-\alpha l})^2 - 2 \epsilon^{-\alpha l} \cos \frac{360l}{n\lambda} (1 - n \cos \theta)}}{2 Z \sqrt{\alpha^2 + \beta^2 (1 - n \cos \theta)^2}} \quad (24)$$

This equation becomes equivalent to (14) if the line has no attenuation. If we set  $\alpha = 0$  in (24), and substitute  $\beta l$  for  $\frac{360l}{n\lambda}$  we get,

$$I_B = \frac{(E_0 \cos \theta) \sqrt{2 - 2 \cos \beta l (1 - n \cos \theta)}}{2 Z \beta (1 - n \cos \theta)}$$

Making use of the trigonometric relation  $1 - \cos a = 2 \sin^2 \frac{1}{2} a$  we get under the radical in the numerator

$$2 - 2 \cos \beta l (1 - n \cos \theta) = 4 \sin^2 \frac{1}{2} \beta l (1 - n \cos \theta)$$

and with this substitution the expression reduces to

$$I_B = \frac{(E_0 \cos \theta) \sin \frac{1}{2} \beta l (1 - n \cos \theta)}{Z \beta (1 - n \cos \theta)}$$

which is the same as (14).

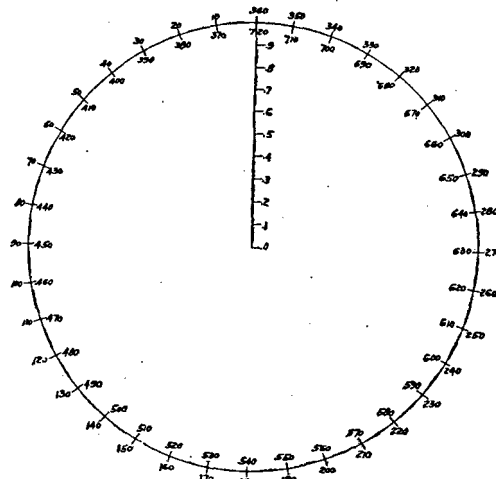

FIG. 34—CHART FOR EVALUATING  $1 - \epsilon^{-\{\alpha + j \frac{\beta l}{n\lambda} (1 - n \cos \theta)\}}$

Fig. 34 shows a chart for use in finding the value of the vector difference in the bracket of (22). The radius of the circle is taken as unity, ten centimeters being a convenient radius. Scale divisions from 0 to 1 are shown on one radius. From a point on this scale corresponding in value to  $\epsilon^{-\alpha l}$ , we measure the distance to a point on the circumference corresponding to the angle  $\beta l (1 - n \cos \theta)$  radians or  $\frac{360l}{n\lambda} (1 - n \cos \theta)$  degrees, and this measurement is the vector difference sought.

Let us apply formula (22) to the calculation of the directive curve of an antenna 12 kilometers long receiving a signal of 12 kilometers wave length, having an attenuation constant  $\alpha = 0.05$  per kilometer, and a wave velocity =  $2.4 \times 10^8$  kilometers per second, or  $n = 0.8$ . The calculations are shown in Table II. Since the

purpose of the directive curve is to show the relative receiver currents for different signal directions, the factor  $\frac{E_0}{22}$  which is the same for all directions, is omitted (or in other words assumed to have a value of 1) and the relative currents shown in column XI are ob-

Figs. 32 to 38 bring out the effects of length, velocity and attenuation on the directive properties of a wave antenna. The value 0.06 per kilometer for  $\alpha$ , and 0.8  $v$  for  $u$ , used in calculating Fig. 36, are mean values ob-

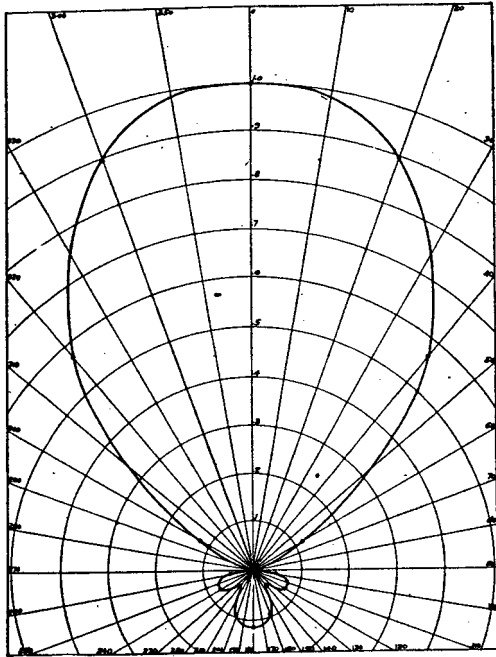

FIG. 35—DIRECTIVE CURVE OF WAVE ANTENNA.  $\lambda = 12 \text{ km.}$ ,  $l = 12 \text{ km.}$ ,  $\alpha = 0.05$ ,  $u = 0.8v$

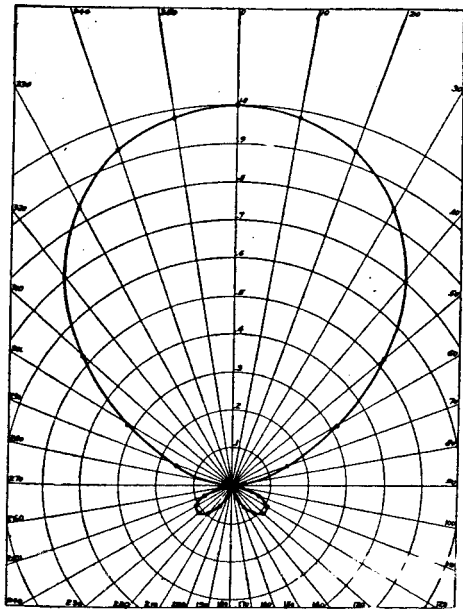

FIG. 36—DIRECTIVE CURRENT OF IDEAL WAVE ANTENNA, ONE WAVE LENGTH LONG.  $\alpha = 0$ ,  $n = 1$ ,  $l = 12$ ,  $\lambda = 12$

tained by dividing all the calculated currents of column X by the largest one of those, which corresponds to  $\theta = 0$ . The corresponding directive curve is shown in Fig. 35.

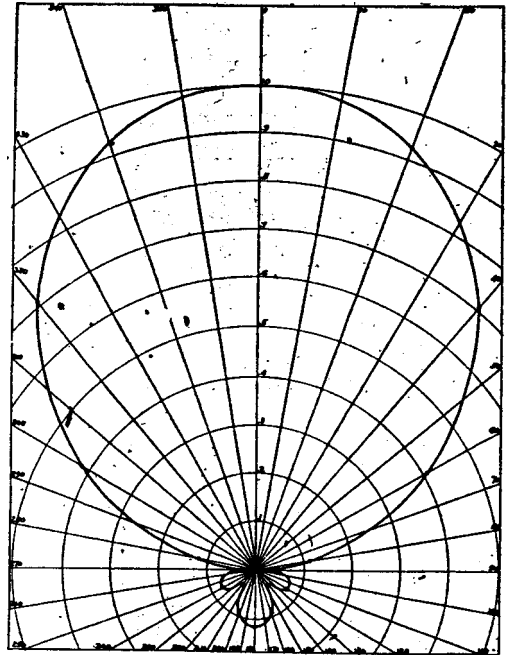

FIG. 37—DIRECTIVE CURVE OF WAVE ANTENNA ONE HALF WAVE LENGTH LONG.  $\lambda = 12 \text{ km.}$ ,  $l = 6 \text{ km.}$ ,  $\alpha = 0.05$ ,  $u = 0.8v$

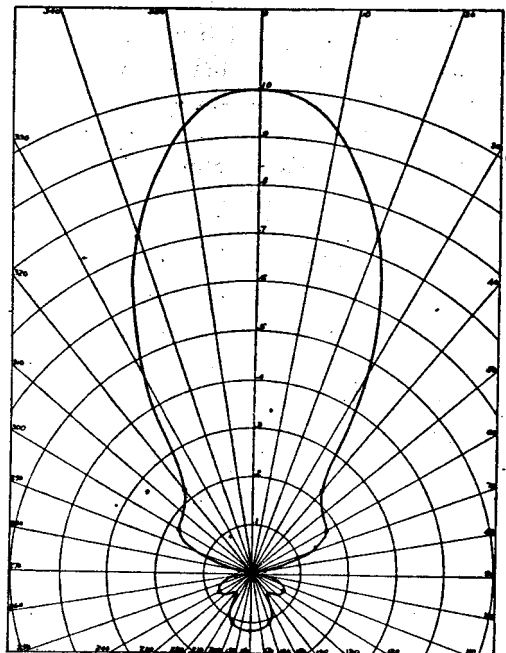

FIG. 38—DIRECTIVE CURVE OF WAVE ANTENNA TWO WAVE LENGTHS LONG.  $\lambda = 12 \text{ km.}$ ,  $l = 24 \text{ km.}$ ,  $\alpha = 0.05$ ,  $u = 0.8v$

served for long waves (7000 to 25,000 meters) on bare 0.102 inch (0.259 cm.) diameter copper wire supported on poles. Fig. 36 shows the directive curve for an antenna one wave length long on the assumption of zero attenuation and light velocity. By analogy with transmission line practise, we have referred to a wave

antenna as "ideal" if it has zero attenuation and light velocity. While Fig. 36 was calculated for a 12 kilometer wave, the directive curve is applicable to any antenna a wave length long, and having full velocity and zero attenuation. The effect of length is shown by a comparison of Figs. 37, 35 and 38, which show the directive curves for antennas of the same constants and 1/2, 1 and 2 wave lengths long respectively. Fig. 39 compared with Fig. 35, shows the effect of reducing the velocity from .8 v to .6 v on a one wave length antenna, and Fig. 40 shows the effect of raising the velocity to 2 v. Fig. 41 is calculated for the same conditions as Fig. 35, except that for Fig. 41, the line losses are twice as high.

**Calculation of Phase Angle.** Equation (22) is a vector equation which determines the magnitude of  $I_b$  and its phase relation with respect to the reference vector  $E$

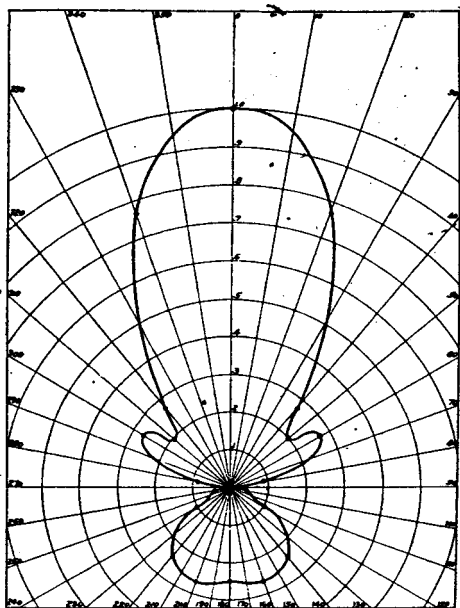

FIG. 39—DIRECTIVE CURVE OF LOW VELOCITY WAVE ANTENNA.  $a = 0.05, n = 0.6, l = 12, \lambda = 12$

It should be recalled that  $E_0$  is defined as the voltage induced per kilometer of antenna at the end "A". For convenience of discussion we will rewrite equation (22a) here

$$I_b = \frac{E_0 \cos \theta}{2 Z} \frac{\epsilon^{-j \frac{2 \pi l}{\lambda} \cos \theta} (1 - \epsilon^{-\alpha l} \epsilon^{-j \frac{2 \pi l}{n \lambda} (1 - n \cos \theta)})}{\alpha + j \frac{2 \pi}{n \lambda} (1 - n \cos \theta)} \quad (22a)$$

In order to find the phase angle of the entire expression, we must first determine the phase angles of the individual vectors of which it is a product.

The first term  $\frac{E_0 \cos \theta}{2 Z}$  is a purely numerical multi-

plier with zero phase angle, when we assume  $Z = \sqrt{L/C}$  and take  $E_0$  as having zero phase angle.

The term  $\epsilon^{-j (2 \pi l / \lambda) \cos \theta}$  is a unit vector having a phase angle  $-\frac{2 \pi l}{\lambda} \cos \theta$  radians or  $-\frac{360 l}{\lambda} \cos \theta$  degrees.

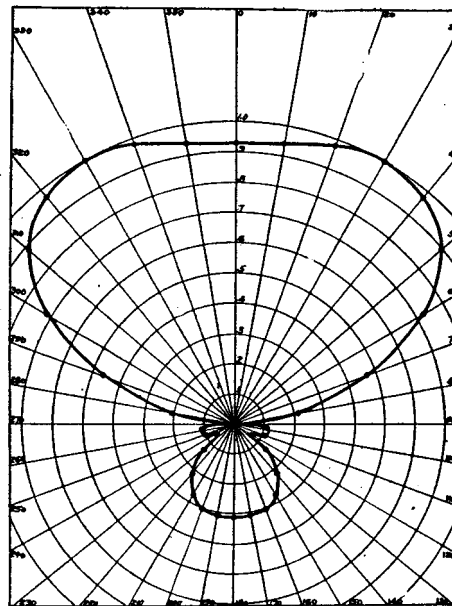

FIG. 40—DIRECTIVE CURVE OF WAVE ANTENNA WITH EXCESSIVE HIGH VELOCITY.  $a = 0.05, n = 2.0, l = 12, \lambda = 12$

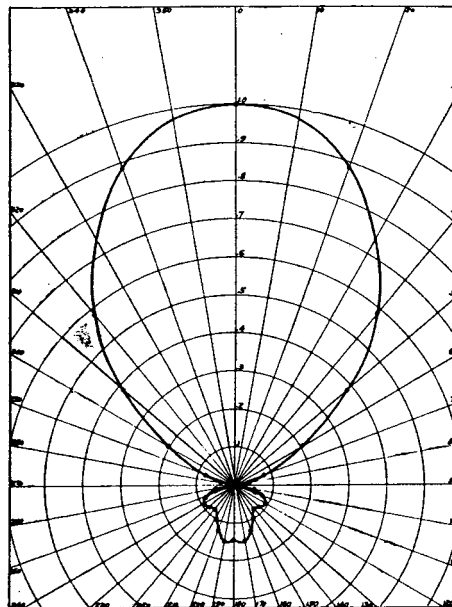

FIG. 41—DIRECTIVE CURVE OF WAVE ANTENNA WITH HIGH ATTENUATION.  $\alpha = 0.10, n = 0.8, l = 12, \lambda = 12$

The bracket is the difference of two vectors, the first a unit vector with zero phase angle, and the second a vector having the absolute value  $\epsilon^{-\alpha l}$  and the phase

$$\text{angle} - \frac{27r}{n \lambda} l (1 - n \cos \theta) \text{ radians or } - \frac{360^\circ l}{n \lambda} (1 - n$$

$\cos \theta^\circ$ ) degrees. The graphical method of finding the magnitude and phase of this vector difference is shown in Fig. 42. Here the unit vector of zero phase angle  $OA$  is drawn horizontally to the right. The vector  $OB$  is then drawn with the length  $\epsilon^{-\alpha l}$  and

phase angle  $-\frac{360^\circ l}{n\lambda} (1 - n \cos \theta^\circ)$ . Then  $BA$  is the vector differencesought. Its magnitude is determined by measuring the length  $BA$  and its phase angle by extending  $OA$  and  $BA$  and measuring the angle between them.

The magnitude of the denominator is

$$\sqrt{\alpha^2 + \left[ \frac{2\pi}{n\lambda} (1 - n \cos \theta) \right]^2}$$

and its phase angle  $\tan^{-1} \frac{\frac{2\pi}{n\lambda} (1 - n \cos \theta)}{\alpha}$

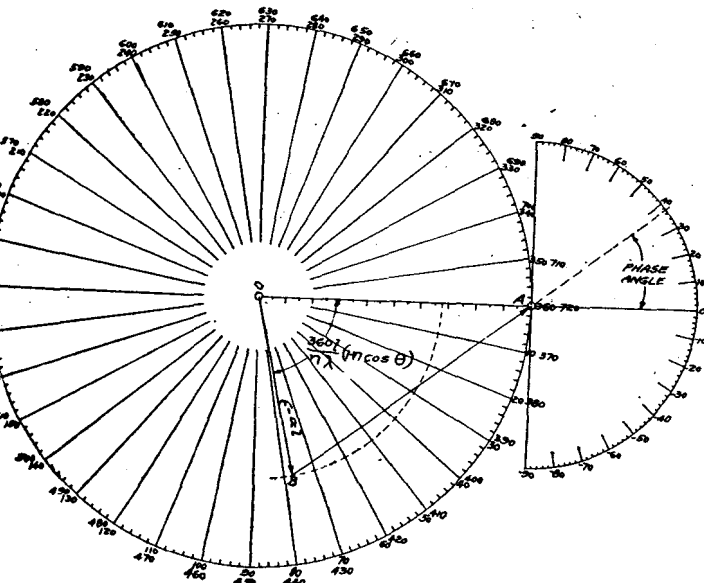

FIG. 42—CHART FOR DETERMINING MAGNITUDE AND PHASE OF

$$\left\{ 1 - \epsilon^{-\alpha l} \epsilon^{-j \frac{2\pi}{n\lambda} l (1 - n \cos \theta)} \right\}$$

We have now determined the magnitude and phase angles of the quantities in the numerator and denominator of the expression for  $I_b$ .

The magnitude of  $I_b$  is obtained by performing the arithmetical operations of multiplication and division using the absolute values of the vector quantities.

The phase angle of  $I_b$  is found by adding together the phase angles of the two vectors occurring as a product in the numerator and subtracting the phase angle of the vector in the denominator.

As an example let us find the magnitude and phase of the current  $I_b$  for an antenna of the following characteristics:

- Wave length  $\lambda = 12$  kilometers
- Antenna length  $l = 12$  kilometers
- Attenuation constant  $\alpha = 0.05$  per kilometer
- Space wave velocity  $v = 3 \times 10^8$  kilometer per second
- Antenna wave velocity  $u = 2.4 \times 10^8$  kilometers per second

Ration =  $u/v = 0.8$  (numeric)

Ratio  $\frac{E_0}{Z} \frac{1}{Z}$  assumed = 1 ampere per kilometer

Angle at which signal strikes antenna =  $\theta$  degrees  
 If we substitute the above values in equation (22a) using the form (absolute magnitude) / Phase angle, to designate a vector quantity, we obtain

$$I_b = \frac{\{1 / -360 \cos \theta\} \{1 / 0^\circ - 0.55 / -450^\circ (1 - 0.8 \cos \theta)\} \cos 6}{\sqrt{(0.05)^2 + [0.654 (1 - 0.8 \cos \theta)]^2} / \tan^{-1} (0.654 (1 - 0.8 \cos \theta) / 0.05)}$$

If we substitute various values of  $\theta$  in this equation, we obtain the magnitude and phase of  $I_b$  as given in Table III. The calculation of magnitudes is taken from Table II, since the constants assumed are the same in the two cases.

Equation (23) or (23a) is the vector equation which determines the magnitude of  $I$ , and its phase relation with respect to the reference vector  $E$ . Equation (23a) is

$$I_a = \frac{E_0 \cos \theta \{1 - \epsilon^{-\alpha l} \epsilon^{-j \frac{2\pi}{n\lambda} l (1 + n \cos \theta)}\}}{2Z \left[ \alpha + j \frac{2\pi}{n\lambda} (1 + n \cos \theta) \right]} \quad (23a)$$

If we substitute the assumed numerical values we obtain

$$I_a = \frac{\{1 - 0.55 / -450^\circ (1 + 0.8 \cos \theta)\} \cos \theta}{\sqrt{(0.05)^2 + [0.654 (1 + 0.8 \cos \theta)]^2} / \tan^{-1} (0.654 (1 + 0.8 \cos \theta) / 0.05)}$$

If we substitute the various values of  $\theta$  in this equation, we obtain the magnitude and phase angle of the current  $I$ , given in Table IV.

**Compensation of Back End Currents.** An example of a problem which requires the calculation of both the magnitude and phase of the end currents is the determination of the directive curve of an antenna in which the current due to waves coming from a particular "back end" direction is "balanced out" by means of some of the current from the other end of the antenna.

Let us imagine there is an intense source of disturbance directly behind the antenna whose directive curve is given in Fig. 35, and for which we have just calculated the magnitude and phase of  $I_b$  and  $I_r$ , and that we wish to neutralize the effect of this disturbance by an adjustment of the damping circuit at  $A$ .

From equation (22) or Table III we have for  $\theta = 180$  deg.,  $I_b = -0.968 / + 301$  deg.

From equation (23) or Table IV we have for  $\theta = 180$  deg.,  $I_r = -8.15 / -40$  deg.

A fraction of  $I_r$  is to be reflected in such phase that it will cancel  $I_b$  in the receiver.

The current in receiver at  $B$  is  $I_b = -0.968 / + 301$  deg.

TABLE III  
MAGNITUDE AND PHASE OF  $I_b$

$l = 12 \text{ Km.}$   $a = -0.06$   
 $\lambda = 12 \text{ Km.}$   $u = 0.8v.$

I	II	III	IV	V	VI	VII	VIII	IX	X	XI	XII	XIII	XIV	XV	XVI	XVII
$\theta$ Signal Angle	Cos $\theta$	$0.8 \cos \theta$	$1 - 0.8 \cos \theta$	$0.654 (1 - 0.8 \cos \theta)$	$\sqrt{(0.5)^2 + \{0.654 (1 - 0.8 \cos \theta)\}^2}$	$-450 \text{ deg. } (1 - 0.8 \cos \theta)$	Vector Difference $\{1 - 0.55 \sqrt{\text{VII}}\}$ from Diagram	VIII/VI	$\text{IX} \cos \theta \frac{E_0}{2Z} = 1$ Magnitude of $I_b$ for $\frac{E_0}{2Z} = 1$	Relative Current $\frac{X}{X + 8.15}$	Angle of VIII from Vector Diagram	$\frac{0.654 (1 - 0.8 \cos \theta)}{0.05}$	Tan $^{-1}$ XIII	XII - XIV	$-360 \text{ deg.} \cos \theta$	XV + XVI Phase Angle of $I_b$
0	1.000	0.800	0.200	0.131	0.140	-90°	1.14	8.15	8.15	1.000	+29°	2.62	69.1°	-40.1	-360	-400.1°
20	0.940	0.752	0.248	0.1625	0.1692	-112	1.30	7.65	7.18	0.880	+24°	3.25	72.9°	-48.9	-338	-386.9°
40	0.766	0.613	0.387	0.253	0.258	-174.0	1.55	6.02	4.61	0.565	+2°	5.07	78.8°	-76.8	-276	-352.8°
60	0.500	0.400	0.600	0.393	0.396	-270.0	1.14	2.88	1.44	0.177	-29°	7.85	82.7°	-111.7	-180	-291.7°
80	0.174	0.139	0.861	0.563	0.565	-387	0.57	1.01	0.175	0.0215	+36°	11.30	85.0°	-59.0	-62.6	-121.6°
100	-0.174	-0.139	1.139	0.744	0.745	-512	1.51	2.03	-0.353	-0.0433	+10°	14.9	86.2°	-76.2	+62.6	-13.6°
120	-0.500	-0.400	1.400	0.916	0.916	-630	1.14	1.245	-0.623	-0.0765	-29°	18.30	86.9°	-115.9	+180	+64.1°
140	-0.766	-0.613	1.613	1.055	1.055	-726	0.46	0.434	-0.333	-0.0408	+8°	21.10	87.3°	-79.3	+276	+196.7°
160	-0.940	-0.752	1.752	1.146	1.146	-788	0.95	0.826	-0.778	-0.0955	+43°	22.90	87.5°	-54.5	+338	+283.5°
180	-1.000	-0.800	1.800	1.176	1.176	-810	1.14	0.970	-0.970	-0.1185	+29°	23.6	87.60°	-58.80	+360	+301.4°

TABLE IV  
MAGNITUDE AND PHASE OR  $I_a$

$l = 12 \text{ km.}$   $a = 05$   
 $\lambda = 12 \text{ km.}$   $u = 0.8v$

I	II	III	IV	V	VI	VII	VIII	IX	X	XI	XII	XIII	XIV	XV
$\theta$ Signal Angle	Cos $\theta$	$0.8 \cos \theta$	$1 + 0.8 \cos \theta$	$0.654 (1 + 0.8 \cos \theta)$	$\sqrt{(0.05)^2 + \{0.654 (1 + 0.8 \cos \theta)\}^2}$	$-450 \text{ deg. } (1 + 0.8 \cos \theta)$	Vector Difference $\{1 - 0.55 \sqrt{\text{VII}}\}$	VII/VI	$\text{IX} \cos \theta \frac{E_0}{2Z} = 1$ Magnitude of $I_a$ for $\frac{E_0}{2Z} = 1$	Relative Current $\frac{X}{X + 8.15}$	Angle of VIII from Vector Diagram	$\frac{0.654 (1 + 0.8 \cos \theta)}{0.05}$	Tan $^{-1}$ XIII	XII - XIV Phase Angle of $I_a$
0	1.000	0.800	1.800	1.176	1.176	-810°	1.14	0.97	0.97	0.1185	+29°		+87.6	-58.6°
20	0.940	0.752	1.752	1.146	1.146	-788°	0.95	0.826	0.778	0.0955	+33°		+87.5	-54.6°
40	0.766	0.613	1.613	1.055	1.055	-726°	0.46	0.434	0.333	0.0408	+8°		+87.3	-79.3°
60	0.500	0.400	1.400	0.916	0.916	-630°	1.14	1.245	0.623	0.0765	-29°		+86.9	-115.9°
80	0.174	0.139	1.139	0.744	0.745	-512°	1.51	2.03	0.353	0.0433	+10°		+86.2	-76.2°
100	-0.174	-0.139	0.861	0.563	0.565	-387°	0.57	1.01	-0.175	-0.0215	+26°		+85.0	-59.0°
120	-0.500	-0.400	0.600	0.393	0.396	-270°	1.14	2.88	-1.44	-0.177	-29°		+82.7	-111.7°
140	-0.766	-0.613	0.387	0.253	0.258	-174°	1.55	6.02	-4.61	-0.565	+2°		+78.8	-76.8°
160	-0.940	-0.752	0.248	0.1625	0.1691	-112°	1.30	7.65	-7.18	-0.880	+24°		+72.9	-48.9°
180	-1.000	-0.800	0.200	0.131	0.140	-90°	1.14	8.15	-8.15	-1.000	+29°		+69.1	-40.1°

The required compensating current at B is  $I_{cb} = -0.968 / + 301 \text{ deg.} - 180 = -0.968 / + 121 \text{ deg.}$

We have taken the compensating current as one half cycle or 180 deg. behind  $I_b$  in phase.

To allow for attenuation, and the time required for propagation from A to B, we must produce by the reflection at A, a current

$$I_r = \frac{-0.968}{e^{-\alpha l}} / + 121^\circ + 450^\circ = -1.76 / + 571$$

The 450 deg. is the angle corresponding to the time of propagation or  $360^\circ \frac{l}{\lambda}$

Thus at A we have available a current  $I_r = -8.15 / -40 \text{ deg.}$  and wish to produce for the purpose of compensation, a current  $I_r = -1.76 / + 571 \text{ deg.}$

This represents a phase advance of 611 deg.

We cannot reflect a wave before it arrives at the reflection point, which such a phase advance implies.

A current, however, which is two complete cycles behind the desired value; that is, to say a current  $-1.76 / + 571 \text{ deg.} - 720 \text{ deg.}$  or  $-1.76 / - 149 \text{ deg.}$  will give cancellation of all but the first two waves of the train, and this current which is  $109 \text{ deg.}$  behind  $I_1$  can be obtained by reflection. Experience has shown that in spite of the failure to neutralize the first two waves in a train, a very high degree of balance is obtainable, both on signals and static.

The terminal impedance required to give a specified reflection, may be determined from the vector relation

$$Z_t = Z \frac{I_1 - I_2}{I_1 + I_2} = Z \frac{1 - \frac{12}{11}}{1 + \frac{12}{11}} \quad (25)^{15}$$

in which  $Z_t$  is the terminal impedance,  $Z$  the surge impedance of the line,  $I_1$  the current due to the oncoming wave and  $I_2$  the current due to the reflected wave. In the present case  $I_1$  is  $I_a$  and  $I_2$  is the desired  $-1.76 / - 149 \text{ deg.}$

Then

$$\frac{12}{11} = \frac{-1.76 / - 149^\circ}{-8.15 / - 40^\circ} = 0.216 / - 109^\circ$$

$$= -0.070 - 0.204j$$

$$1 - \frac{12}{11} = 1.070 + 0.204j$$

$$1 + \frac{12}{11} = 0.930 - 0.204j$$

$$\frac{1 - I_2/I_1}{1 + I_2/I_1} = \frac{1.070 + 0.204j}{0.930 - 0.204j} = 1.055 + 0.450j$$

Substituting this value in (25) we have

$$Z_t = Z (1.055 + 0.450j)$$

If the line surge impedance  $Z$  is 500 ohms, (with zero phase angle) the terminal impedance to give the desired neutralization would be 500  $(1.055 + 0.450j)$  or 527 ohms of non-inductive resistance and 225 ohms of inductive reactance.

Placing this impedance in the ground circuit at A will cause a similar reflection of all waves of the same length reaching A, whether due to a signal in line with the antenna or to a disturbance coming from a different direction; That is to say the reflected wave will in each case be 0.216 of the magnitude of the oncoming wave, and  $109 \text{ deg.}$  behind it in phase. When the reflected wave reaches the end B, its amplitude will be reduced to  $0.55 \times 0.216 = 0.119$  of that of  $I_1$  and its phase will be further retarded by  $450 \text{ deg.}$  giving a total lag of  $559 \text{ deg.}$  behind  $I_1$ . Thus to find the directive curve of the antenna with the impedance described at A, we calculate  $I$ , by equation (22), for each value of  $\theta \text{ deg.}$ , determining the phase angle of  $I$ , as well as its magnitude, multiply its magnitude by 0.119, retard its phase by  $559 \text{ deg.}$  and find the resultant when it is added vectorially to  $I_b$ , calculated by formula (23) for the same value of  $8 \text{ deg.}$

Fig. 43 shows the relations between  $I_b$ ,  $I$ , and the reflected current, for  $\theta = 180 \text{ deg.}$

In Table V we have given the calculations for the

15. See page for derivation.

directive curve of the compensated antenna. The magnitudes and phase angles of  $I_1$  and  $I_b$  are taken from Tables III and IV. Instead, however, of rotating  $0.119 I_a$  backward by  $559 \text{ deg.}$  and adding it vectorially to  $I_b$ , we have rotated it  $180 \text{ deg.}$  less, and subtracted it vertically from  $I_b$ , which is an easier operation to perform and gives the same result. This backward rotation of  $379 \text{ deg.}$ , is, for the purpose of finding the vector difference, equivalent to one of  $(379 \text{ deg.} - 360 \text{ deg.}) = 19 \text{ deg.}$  The table shows the values of  $0.119 I_a$ , rotated backward  $19 \text{ deg.}$ , and the vector difference found by subtracting this from the corresponding  $I_b$ . Thus to find the directive curve of any compensated antenna, we first choose the direction for which we wish to have zero reception. Then we compare  $I_a$  and  $I_b$  for this value of  $\theta \text{ deg.}$  and determine the factor by which  $I_a$  must be multiplied and the angle through which it must be rotated to make it coincide with  $I_b$ . Then for each other value of  $\theta \text{ deg.}$  we multiply  $I_a$  by the same ratio and rotate it through the same angle, and subtract the vector so found, vectorially from  $I_b$ .

Inspection of the table shows that in the example we have worked out, the effect of the reflection on the

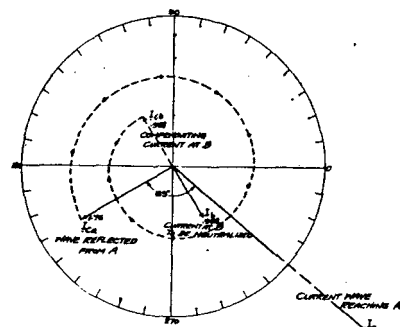

FIG. 43—VECTOR RELATIONS IN COMPENSATION PROBLEM

receiver current is negligible for values of  $\theta$  less than  $90 \text{ deg.}$  Therefore, the front end of the directive curve is not appreciably altered or the reception of the desired signal affected by the reflection we have been considering.

Fig. 44 shows the directive curve plotted from the calculations given above. This is for the same antenna and same conditions as Fig. 35, except that the "reflection balance" has been applied to give zero reception from the back.

In the case of an antenna producing relatively large back end currents, as, for example, a quarter wave length antenna, the front end of the directive curve would be considerably affected by a reflection designed to produce zero back end reception.

*Effect of Reflection at Receiver End.* The effect of reflection at the receiver end of the antenna may be shown as follows:

Let  $I_b$  = Wave built up on wire by signal at end B (Equation 22)

I	XVIII	XIX	XX	XXI	XXII	XXIII	XXIV	XXV	XXVI
$\theta$ Signal Angle	Magnitude of $I_c$ Table IV Column X	Magnitude of Compensating Current - $I_c$ XVIII $\times$ 0.119	Magnitude of $I_b$ Table III Column X	Angle of $I_c$ Table IV Column XV	Angle of $I_c$ XXI - 18.5	Angle of $I_b$ Table III Column XVII	Angle between $I_b$ and $I_c$ XXIII - XXII	Vector Difference $I_b - I_c$	XXV + 8.05
0	0.97	0.115	8.15	-58.60	-77.1	-400.1°	-323.0	8.05	1.00
20	0.778	0.093	7.18	-54.50	-73.0	-386.9°	-313.9	7.12	0.883
40	0.333	0.040	4.61	-79.30	-97.8	-352.8°	-255.0	4.62	0.573
60	0.623	0.074	1.44	-115.9°	-134.4	-291.7	-157.3	1.51	0.187
80	0.353	0.042	1.75	-76.2°	-94.7	-121.6°	-26.9	1.72	0.213
100	-0.175	-0.021	-0.353	-59.0°	-77.5	-13.6°	+63.9	0.343	0.043
120	-1.44	-0.172	-0.623	-111.7°	-130.2	+64.1	+194.3	0.79	0.098
140	-4.61	-0.55	-0.333	-76.8°	-95.3	+196.7°	+292.0	0.53	0.066
160	-7.18	-0.855	-0.778	-48.9°	-67.4	+283.5°	+350.9	0.16	0.020
180	-8.15	-0.970	-0.970	-40.1°	-58.6	+301.4°	+360.0	0	0

I, = Total oncoming wave at B (Resultant of  $I_b$  and other waves traveling in same direction resulting from reflections at A.)  
 I, = Receiver current or total current at B, = resultant of total oncoming wave I, and reflected wave at B.

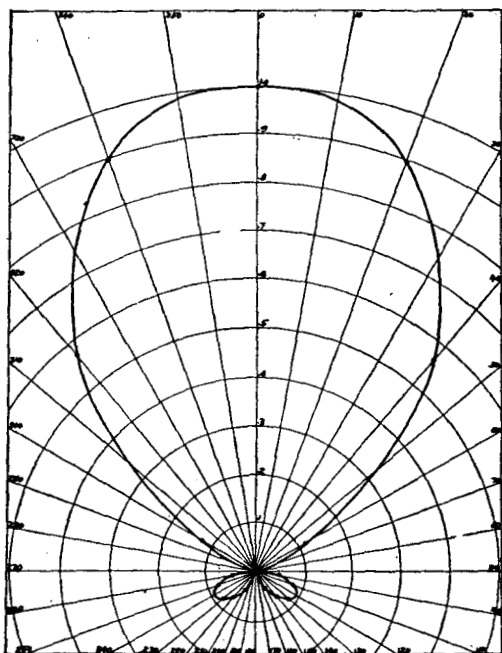

FIG. 44—DIRECTIVE CURVE OF WAVE ANTENNA. COMPENSATED BY REFLECTION FOR ZERO BACK END.  $\lambda = 12$  KM.,  $l = 12$  KM.,  $a = 0.05$ ,  $v = 0.8v$

I, = Current built up on wire at A by signal (Equation 23)  
 $I_A$  = Total oncoming wave at A (wave moving in direction B to A) or resultant of  $I_1$  and other waves in same direction resulting from reflections at B.

$b$  = reflection coefficient<sup>s</sup> at B or vector ratio of reflected to oncoming waves at B.

$$d = b e^{-(\alpha + j\beta)l}$$

$a$  = reflection coefficient at A

$$c = a e^{-(\alpha + j\beta)l}$$

At B we have the oncoming wave,  $I$ , and reflected wave  $b I_b$  giving the resultant current

$$I_R = I_b (1 + b) \tag{26}$$

The wave  $b I_b$ , reflected from B becomes  $b I_b e^{-(\alpha + j\beta)l}$  or  $d I_b$  when it reaches A. It combines with  $I_a$  (the wave built up on the wire toward A) producing a total wave at A

$$I_A = I_a + d I_b \tag{27}$$

Likewise the wave  $a I_a$ , reflected from A becomes  $a I_a e^{-(\alpha + j\beta)l} = c I_a$ , when it reaches B. It combines with  $I_b$  (built up on the wire between A and B) giving a total wave reaching B

$$I_B = I_b + c I_a \tag{28}$$

From (28)

$$I_A = \frac{I_B - I_b}{c}$$

Equating this to (27)

$$\frac{I_B - I_b}{c} = I_a + d I_b$$

Solving for  $I$ ,

$$\begin{aligned} I_B - I_b &= c I_a + c d I_b \\ I_B (1 - c d) &= I_b + c I_a \\ I_B &= \frac{I_b + c I_a}{1 - c d} \end{aligned} \tag{29}$$

16. The reflection coefficient is shown in equation (44) to be  $I_2/I_1 = \frac{1 - Z_t/Z}{1 + Z_t/Z}$  in which  $I_2$  = current of reflected wave  
 $I_1$  = current of oncoming wave  
 $Z$  = surge-impedance of line  
 $Z_t$  = impedance of terminal circuit

From (26) the total current in the receiver is

$$I_r = I_b (1 + b) = \frac{1 + b}{1 - cd} (I_b + c I_a) \quad (30)$$

When there was no reflection at *B* we had a receiver current

$$I_r = I_b + c I_a$$

We now have a receiver current in which *I<sub>b</sub>* and *I<sub>a</sub>* are combined in exactly the same manner, but their

resultant is multiplied by the factor  $\frac{1 + b}{1 - cd}$ , which

being a function of line length and terminal conditions only, and not a function of *I<sub>a</sub>*, *I<sub>b</sub>*, or signal direction 8 deg. does not alter the directive properties of the antenna.

The relation shown in (30) is strictly true only for steady state conditions. Let us illustrate what occurs when a train of waves first reaches the antenna. To take a simple case we may assume *I<sub>a</sub>* = 0, so that (30)

becomes  $I_r = I_b \frac{1 + b}{1 - cd}$  as the ultimate current.

When the first wave *I<sub>b</sub>* reaches *B* and is reflected the total current at *B* is

$$I_b (1 + b)$$

The reflected wave reaches *A* with a value *d I<sub>b</sub>*, is reflected back and reaches *B* with a value *cd I<sub>b</sub>*, giving a total wave *I<sub>b</sub> (1 + cd)* which by reflection at *B* produces a receiver current *(1 + b) I<sub>b</sub> (1 + cd)*.

After a second double reflection the total oncoming wave at *B* is made up of the wave *I<sub>b</sub>* reaching the receiver for the first time, a wave *cd I<sub>b</sub>* which has been reflected down the line and back, and a wave *c<sup>2</sup> d<sup>2</sup> I<sub>b</sub>* which has been down the line and back twice. The total oncoming wave *I<sub>b</sub> (1 + cd + c<sup>2</sup> d<sup>2</sup>)* by reflection at *B* produces a receiver current

$$(1 + b) I_b (1 + cd + c^2 d^2)$$

After a large number of reflections the receiver current is

$$(1 + b) I_b (1 + cd + c^2 d^2 + c^3 d^3 + c^4 d^4 + \dots) = (1 + b) I_b \frac{1}{1 - cd} = I_b \frac{1 + b}{1 - cd} \text{ as given by (30)}$$

If the reflection coefficient at either *A* or *B* is small (which is generally true) or if the line attenuation is high, *cd* will be small and the steady state value of receiver current is approached very quickly.

Let us apply equation 30 to the case of the compensated 12 kilometer antenna whose directive curve is shown in Fig. 44. Here in order to give zero reception for  $\theta = 180^\circ$ , we produced a reflection at *A* such as to give a current at *B* whose magnitude is 0.119 of that of *I<sub>a</sub>* and whose phase is 559 deg. behind *I<sub>a</sub>*. Hence

$$c = 0.119 e^{j(-559^\circ/57.3^\circ)}$$

Suppose that instead of the surge impedance at the

receiver end, we have a transformer having 400 ohms inductive reactance and 100 ohms effective resistance. Taking the surge impedance of the antenna as 500 ohms (non inductive) the reflection coefficient at *B* will be

$$b = \frac{1 - Z_i/Z}{1 + Z_i/Z} = \frac{1 - (0.2 + 0.8j)}{1 + (0.2 + 8j)} = \frac{0.8 - 0.8j}{1.2 + 0.8j} = 0.12 - 0.6j = 0.612 e^{j(-79^\circ/57.3^\circ)}$$

Since

$$e^{-(\alpha + j\beta)l} = 0.55 e^{j(-450^\circ/57.3^\circ)}$$

$$d = b e^{-(\alpha + j\beta)l} = 0.336 e^{j(-529^\circ/57.3^\circ)}$$

and

$$cd = 0.04 e^{j(-1088^\circ/57.3^\circ)} = 0.04 (\cos 1088^\circ + j \sin 1088^\circ) = 0.0396 - 0.0056j$$

$$\frac{1 + b}{1 - cd} = \frac{1.12 - 0.6j}{0.9604 + 0.0056j} = 1.163 - 0.63j = 1.323 e^{j(-28.5^\circ/57.3^\circ)}$$

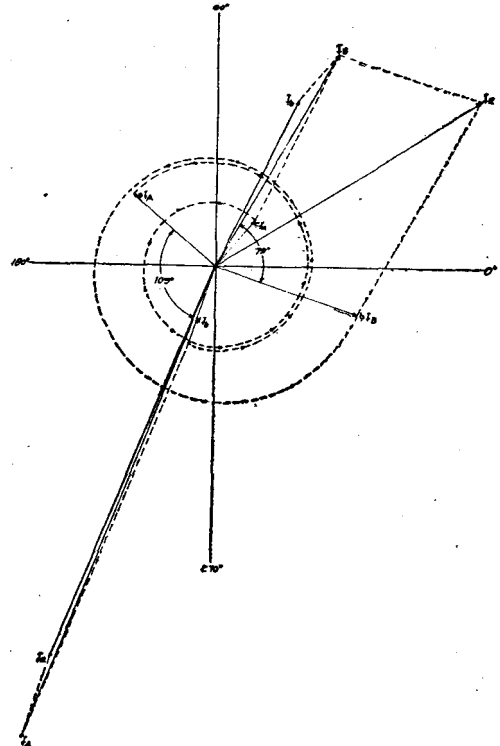

FIG. 45—VECTOR RELATIONS IN DOUBLE REFLECTION PROBLEM

Without reflection at *B*, the receiver current of the compensated antenna, as shown in Column XVII of Table V was *I<sub>b</sub> + c I<sub>a</sub>* or *I<sub>b</sub> + I<sub>a</sub> × 0.119 e<sup>j(-559°/57.3°)</sup>*

With the reflections caused by the receiver circuit we have just been considering the current in the transformer primary will be

$$1.323 e^{j(-28.5^\circ/57.3^\circ)} (I_b + I_a \times 0.119 e^{j(-559^\circ/57.3^\circ)})$$

or a current of 32.3 per cent greater for each value of 8 than that given in column XVII of Table V. The directive curve or relative current for different values of 8 is the same as before. Fig. 45 shows the vector relations of the currents at the ends of the line, for the



signal direction  $\theta = 120$  deg. Both  $I_b$  and  $I$ , as given by formulas (22) and (23) have negative signs, and the negative signs are retained throughout rather than reversing the vectors in the diagrams, which would somewhat obscure the angular relations. If the entire diagram is turned 180 deg. (looked at up side down) the vectors appear in their true positions.

**Short. Antennas.** The question of the possibility of obtaining in less space directive properties approaching those of a full wave length antenna is of considerable

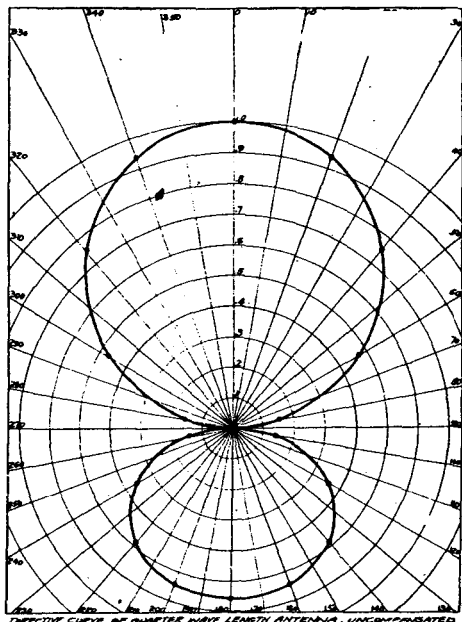

FIG. 47— $l = 3, \lambda = 12, a = 0.5, n = 0.8$

interest. Fig. 47 shows the directive curve of a quarter wave antenna without compensation. It is obvious that so long as there is considerable inequality in the size of the two lobes of a figure-eight directive curve such as Fig. 47, a back end zero can be obtained by compensation without entirely sacrificing the signal, or front end reception, but how favorable a total directive curve would result is not apparent until detailed calculations are made.

Among the first experiments tried on the Riverhead antenna was loading to give various propagation velocities. It was pointed out at that time by Rice that reducing the velocity on a full wave length antenna to something less than the velocity of light would result in a sharper directive curve, but tests showed that the natural velocity of the line was so nearly equal to the best velocity that there was little to be gained by loading. The urgent problem at the time was to obtain the best possible reception of European signals, utilizing as much space as seemed conducive to this result. Tests had shown the half wave antenna, with back end compensation, to be definitely inferior to the full wave length antenna. The question of short antennas was therefore not investigated until some months later when the principal engineering problems connected with

multiplex reception with the wave antenna had been worked out.

At the suggestion of Mr. R. H. Ranger, of the Radio Corporation, calculations were made by Kellogg of the directive properties of short antennas on which the velocity had been reduced by loading to the best value for the wave length and antenna length in question. Mr. Ranger reasoned that since reducing the velocity sharpened the directive curve of a full wave length antenna, it might be possible, by sufficiently reducing the velocity, to compensate for reduced length and perhaps obtain a good directive curve in very small space. The most favorable velocity was found to be that which gave zero (or minimum) reception at the back end, without compensation. The condition for this is that

$$v/u = \lambda/l - 1$$

in which  $l$  is the length of the antenna

$v$  is the velocity of light

$u$  is the antenna velocity

$\lambda$  is the wave length

Figs. 48 and 49 show directive curves for quarter and eighth wave length antennas with velocities equal to one third and one seventh of that of light respectively in accordance with the above equation.

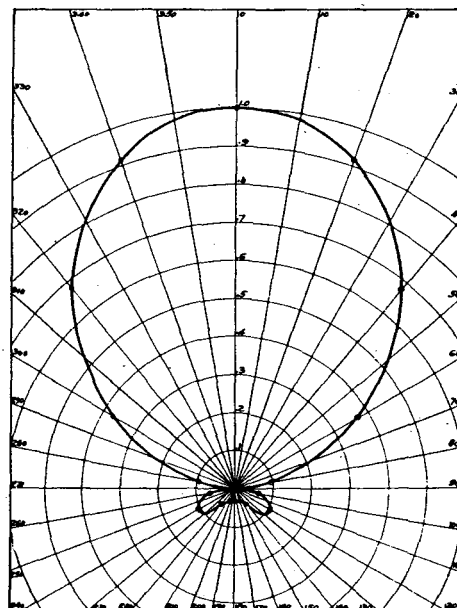

FIG. 48—DIRECTIVE CURVE OF SLOWED DOWN QUARTER WAVE LENGTH ANTENNA  $\alpha = 0.5, n = 0.333, l = 3, \lambda = 12$

By way of comparison, the directive curves Figs. 50 and 51 have been calculated for compensated antennas without loading. The back end areas of these curves are seen to be slightly greater.

Multiplex reception with different compensation for each wave length is possible with the unloaded, compensated antennas. On the other hand, with the slowed down antenna, the velocity is right only for one wave length. In order to receive other wave lengths, compensation would be employed in addition to the loading.

Fig. 62 shows the directive curve for an 18 kilometer wave length of the slowed down antenna, whose directive curve for  $\lambda = 12$  kilometers is shown in Fig. 48. The dotted line A shows the directive properties without compensation and the solid line B is the directive curve with compensation. Fig. 53 shows the directive curve for the same antenna receiving an eight

Compared with the simple unloaded, compensated antenna, the slowed down antenna has a better directive curve at one wave length, but a narrower range of satisfactory multiplex reception. The signal strength

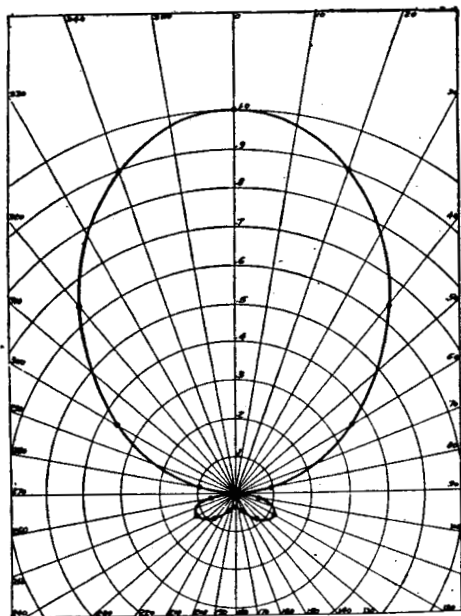

FIG. 49—DIRECTIVE CURVE OF SLOWED DOWN EIGHTH WAVE LENGTH ANTENNA.  $\alpha = 0.5, n = 0.143, l = 1.5, \lambda = 12$

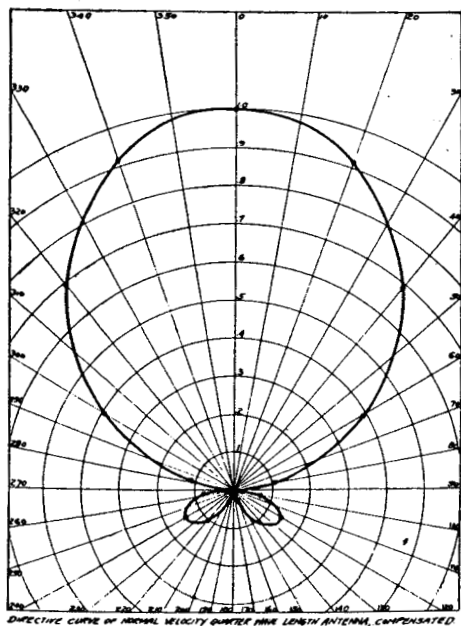

FIG. 50—DIRECTIVE CURVE OF NORMAL VELOCITY, QUARTER WAVE LENGTH ANTENNA, COMPENSATED.  $l = 3, \lambda = 12, \alpha = 0.5, n = 0.8$

kilometer wave. We observe that the slowed down antenna can be multiplexed by compensation and receive longer waves than that for which its velocity is adjusted, but that for shorter waves it is unfavorable.

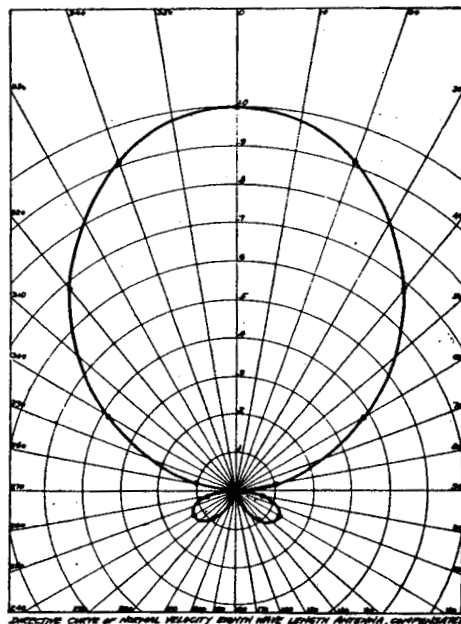

FIG. 51— $l = 1.5, \lambda = 12, a = 0.5, n = 0.8$

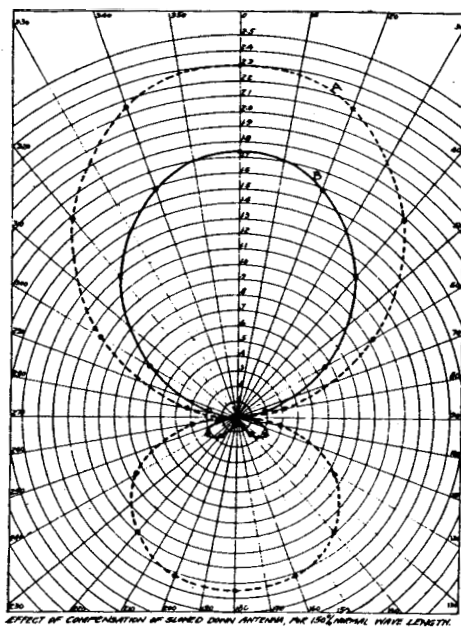

FIG. 52—A UNCOMPENSATED. B COMPENSATED.  $l = 3 \text{ EM.}, \lambda = 18, \alpha = .05, n = 0.333$

is of the same order of magnitude on both—considerably less than on an uncompensated full velocity antenna of the same length. The intensity factor or receiver

current per unit value of the quantity  $\frac{E_0}{2Z}$  in equation (22), is shown in Table VI for the short antennas whose directive curves are given in Figs. 47 to 53. The

TABLE VI  
RELATIVE SIGNAL INTENSITIES ON SHORT ANTENNAS

	Antenna Length Kilometers $l$	Wave Length Kilometers $\lambda$	velocity Ratio $n$	Attenuation Constant $a$	Directive Curve Figure No.	Intensity Factor
Ideal Antenna, one eighth wave length long, Uncompensated.....	1.6	12	1.0	0.0		1.6
Average Unloaded Antenna, $l = 1/8 \lambda$ , Uncompensated, .....	1.5	12	0.8	0.05		1.44
Same, Compensated for zero reception at $\theta = 180$ deg.....	1.6	12	0.8	0.05	51	0.33
Slowed-down Antenna $l = 1/8 \lambda$ , No compensation.....	1.6	12	0.143	0.06	49	0.44
Ideal, Quarter-wave-length Antenna, Uncompensated.....	3	12	1.0	0		3.0
Average Unloaded Antenna $l = 1/4 \lambda$ , Uncompensated, .....	3	12	0.8	0.06	47	2.8
Same, Compensated to give zero reception for $\theta = 180$ deg. . .	3	12	0.8	0.06	50	1.92
Slowed-down, Quarter-wave Antenna, $l = 1/4 \lambda$ , No Compensation	3	12	0.333	0.05	48	1.78
Same, Compensated to give zero reception at $\theta = 180$ deg., for $\lambda = 18$ .....	3	18	0.333	0.05	52	1.73
Same, Compensated to give zero reception at $\theta = 180$ deg., for $\lambda = 8$ .....	3	8	0.333	0.06	53	0.44
Average Antenna, one wave length long, .....	12	12	0.8	0.05	35	8.15

intensity factor for a full velocity, zero attenuation line is included for reference.

It will be observed that in all cases where unidirectional properties are obtained on an antenna a small fraction of a wave length long, there is considerable sacrifice of signal intensity. If this could be made up with amplification the disadvantage would not be serious. Residual voltages are, however, inevitable

ing, be kept negligibly small compared with the signal, but if the signal produced by the antenna is weak, or if it is a small remainder after comparatively strong currents are combined to give neutralization for a certain direction, the directive properties actually obtained are likely to be decidedly inferior to those indicated by calculations, based on assumed ideal conditions.

Wherever possible, therefore, the writers have advocated building full wave length or at least, half wave length antennas for commercial reception.

FUNDAMENTAL EXPERIMENTS

While for the most part the experimental work on the wave antenna has been directed toward practical utilization, some tests have been carried out whose purpose was the verification of theory: That the waves built up on the wire in the direction of signal travel, as indicated by the mathematical analysis, had been shown qualitatively by Beverage's early data, some of which is given in curve form in Fig. 2. The series condensers also worked just as predicted by the theory.

**Tests Bearing on Wave Tilt Theory.** A question which was at first the subject of some discussion among those interested in the wave antenna was whether the collection of energy from the space wave depended on wave front tilt, or upon the height of the wire above the earth and the space potential corresponding to its position. If a signal causes a vertical potential gradient  $+G$  volts per meter, a wire  $h$  meters above earth would tend to assume the potential  $+Gh$ . A half wave length away where the potential gradient due to the signal wave is  $-G$ ; the wire would tend to assume the potential  $-Gh$ , and the potential difference along the wire would give rise to a current. According to such a picture the wave antenna would be equivalent to an infinite number of small static antennas whose charging current is carried over the line to the ends. If a formula for the end current is worked out on this basis it shows the same directive properties as the formula we have developed, except that the factor  $\cos \theta$  by which  $E_0$  is multiplied in (22) is omitted. Thus in Table II we should use the figures in column IX instead of column

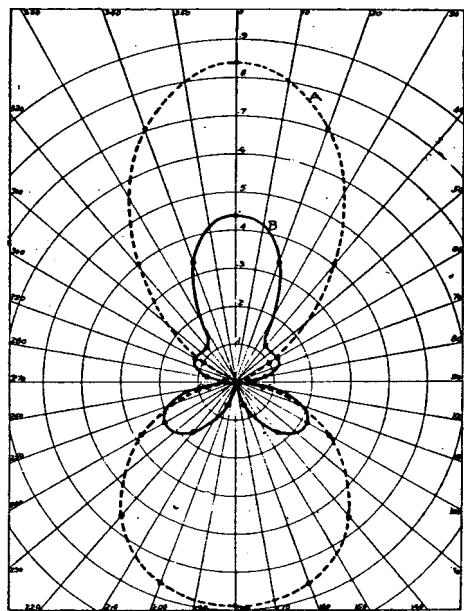

FIG. 53—A UNCOMPENSATED. B COMPENSATED.  $l = 3$ ,  $\lambda = 8$ ,  $a = 0.5$ ,  $n = 0.333$

in radio receiving' systems. For example, electromotive forces are induced in the end verticals, of which no account is taken in the calculations given here; foreign circuits at crossings or unavoidable short parallels induce electromotive forces in the antenna wires, transmission lines used to carry signal or compensating currents are not absolutely quiet, transformer or receiving circuit coils pick up some disturbances, and where high amplification is employed tube noises are a factor. With strong signals such as obtained with full length antennas, these effects may, by careful engineer-

**X** to obtain the directive curve. The difference is especially marked in the case of a **half** wave length antenna with signals coming at right angles to the antenna. If the half wave length wave antenna were acting like a series of static antennas the reception for  $\theta = 90$  deg. would be about half of the full intensity or **half** that for  $\theta = 0$ . On the other hand if the wave antenna depends on wave front tilt the reception from **90 deg.** to the antenna would be zero for all lengths. As a test of this the Belmar wave antenna was cut at a point about 5.8 kilometers from the station, giving a short antenna, with the 200 kw. New Brunswick sending station ( $\lambda = 13,600$  meters) on 'the side. The reception of New Brunswick, only 50 miles away, was of the same order of intensity as European stations, thus indicating that the half wave antenna was substantially dead on the side.

When the new antenna at Riverhead was completed, it afforded an opportunity to test a long loop, as a receiving circuit. The two top wires which were 9 meters above ground were connected through from Riverhead to Terrell River or the full length of the antenna, and two of the lower wires which were about  $5\frac{1}{2}$  meters above ground, were similarly connected through. The upper and lower wires were connected together through a damping resistance at Riverhead (the north-east end), and the receiving set was connected between the upper and lower wires at Terrell River. European signals were extremely weak on this loop, as compared with intensity obtained when the receiving set was connected from either pair or wires to ground. In the latter case there appeared to be no choice between the upper and lower wires.

In other words there is no differential effect due to the difference in height of the wires. The effect of height was again tested at Schenectady using a wave length of 120 meters and a wire one wave length long at heights ranging from 0.8 meters to 2.9 meters. The received current was found to be practically independent of the height. This is what would be expected from an antenna which works by virtue of the forward tilt of the wave front. If the currents in the antenna were due to the space potential of the wire above ground the received current would be proportional to the height of the wire.

There is another conclusion which follows from the theory that the action of the wave antenna depends upon the tilt of the wave front. Low, wet ground, or salt marsh would be an unfavorable location so far as signal intensity is concerned. No experimental evidence on this point has come to the writers' attention. Before conclusions can be drawn from tests or comparisons it is necessary to make sure that conditions are the same in other respects. In one instance with which the writers are familiar, two antennas, in locations several miles apart were constructed parallel and as much alike as possible. One followed a small stream and the other was over comparatively dry ground. The two antennas gave substantially equal signal intensities. Presum-

ably in this case the low resistance ground was too restricted and local to have any appreciable effect on the tilt of the twelve to fourteen kilometer waves on which the observations were made. For ground of a given resistance the wave front tilt increases as the wave length decreases, and for short waves (less than 1000 meters) there is a substantial tilt, sufficient for satisfactory operation even over wet ground.

Zenneck<sup>17</sup> has worked out equations for the forward tilt of the wave front as a function of wave length, and the specific resistance and dielectric constant of the soil. The tilt is expressed as the ratio of the horizontal to the vertical potential gradient of the space wave.

In its general form Zenneck's formula is -

$$X/Z = \sqrt{\frac{g + j \omega c}{g' + j \omega c'}} \tag{31}$$

in which

**X** is the horizontal potential gradient of the space-wave  
**Z** is the vertical potential gradient of the space-wave  
**g** is the leakage conductance between parallel faces of a centimeter cube of air

**g'** is the leakage conductance between parallel faces of a centimeter cube of ground

**c** is the capacity between parallel faces of a centimeter cube of air

**c'** is the capacity between parallel faces of a centimeter cube of ground

For all practical purposes the conductance **g** for air is zero, so that the formula becomes

$$X/Z = \sqrt{\frac{j \omega c}{g' + j \omega c'}} \tag{32}$$

Expressed in electrostatic units

$$g' = \frac{9 \times 10^{11}}{\rho}$$

$$c = \frac{1}{41r}$$

$$c' = \frac{K}{41r}$$

in which  $\rho$  is the specific resistance of the earth in ohms for a centimeter cube, and  $K$  is the dielectric constant of the earth. Average values of  $\rho$  and  $K$  as given in Fleming<sup>18</sup> are shown in Table VII.

TABLE VII.

	$\rho =$ Ohms per centimeter cube	$k =$ Dielectric constant
Sea Water.....	100	80
Fresh Water.....	10,000 to 100,000	80
Moist Earth.....	1000 to 100,000	5 to 15
Dry Earth.....	1,000,000 and up	2 to 6
Wet Sand.....	100 to 10,000	9
Dry River Band.....	very large	2-3
Wet Clay.....	100 to 10,000	
Dry Clay.....	1,000,000 and up	2-5

Fig. 55 shows the values of  $X/Z$  for various values of wave length  $\lambda$ , specific resistance  $\rho$  and dielectric constant  $K$ . With long waves and low-resistance soils  $\omega c'$  is negligible compared with  $g'$ , in which case

$$X/Z = \sqrt{\frac{j \omega c}{g'}} \quad (33)$$

This is a function of wave length and specific resistance, and is shown in the sloping lines of Fig. 55. On the other hand if the waves are so short and the soil resistance so high that  $g'$  is negligible compared with  $\omega c'$  we have

$$X/Z = \sqrt{C/C'} = \sqrt{1/K} \quad (34)$$

which is independent of wave length or soil conductivity and is shown for several values of  $K$  in the horizontal lines at the top of the figure. To find the value of  $X/Z$  for a certain wave length and a soil of a given resistivity and dielectric constant we use whichever curve (the sloping line of equation (33) or the horizontal line of equation (34) gives the lower value for  $X/Z$ . If near the intersection of the two straight lines we use the

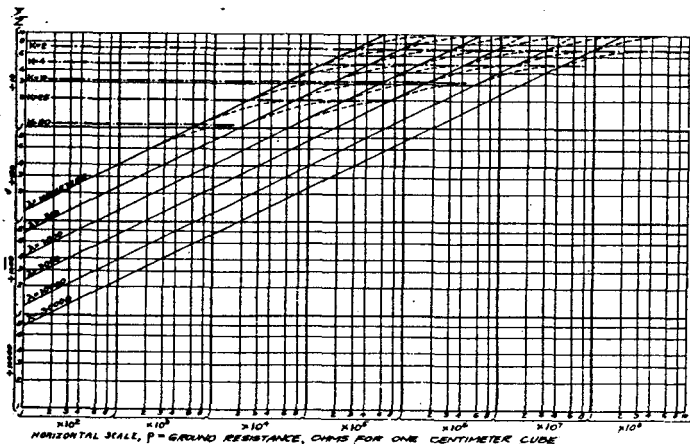

FIG. 55—WAVE FRONT TILT,  $X/Z$  BY ZENNECK'S FORMULA

transition curve which is shown dotted. To illustrate, if  $\lambda = 1000$  meters and  $K = 4$ , we find

- $X/Z = 1.3 \div 10$  for  $\rho = 1 \times 10^5$
- $2.5 \div 10$  for  $\rho = 4 \times 10^5$
- $3.9 \div 10$  for  $\rho = 1 \times 10^6$  . (on transition curve)
- $4.9 \div 10$  for  $\rho = 4 \times 10^6$  or greater. (On horizontal line for  $K = 4$ ).

It will be noted that in Zenneck's formula (32), the ratio  $X/Z$  is a vector quantity whose phase angle ranges from 0 deg. to 45 deg. By far the most common condition is that  $g'$  greatly exceeds  $\omega c'$  (i. e. the earth carries current by conduction rather than by capacity) in which case the phase angle is nearly 45 deg. The phase difference means that the vertical and horizontal potential gradients do not become zero simultaneously, but the electric field is a rotating one, Under these circumstances if a straight conductor is held in various positions in a vertical plane parallel to the direction of wave propagation, there will be no direction of the con-

ductor in which the electromotive force induced in it is zero. This may account for the doubtful results obtained in attempts to measure wave tilt by observing the angle of zero or minimum electromotive force in a straight conductor rotated in a vertical plane parallel to the signal direction. Wherever the tilt is considerable so that it might be readily measured, the minimum is correspondingly dull.

More satisfactory as a test of the theoretical conclusions, would be quantitative measurements of the relative magnitudes of the electromotive forces induced in horizontal and vertical conductors, for various wave lengths and ground conductivities. Determination of the phase relations would provide a further check.

An observation of relative signal intensities on a large loop and a wave antenna, indicated a wave tilt of the order of magnitude called for by Zenneck's formula, but little data of this kind have been taken. The large values of horizontal voltage gradient found in the measurements mentioned below by Beverage and Weinberger were at first considered greater than could be accounted for by wave tilt. Assuming probable values of ground resistance, the ratio of horizontal to vertical potential gradient according to Zenneck's formula is of the order of magnitude of one or two per cent, whereas the measured horizontal gradient was about 30 per cent of the vertical gradient calculated by Austin's formula. The space potential theory of action however is still less capable of accounting for the potentials observed. If we assume ground water to be 100 feet (30 meters) below the surface of the ground, and the earth above ground water level to have a specific resistance of  $2 \times 10^6$  ohms per centimeter cube, which is about the value found by measurement, we find for a 15,000 meter wave length that the potential difference between ground water and surface would be less than that corresponding to a difference of elevation of two feet in the space above ground. Considering the ground as constant potential, and expressing the vertical potential gradient as  $G \epsilon^{-j(2\pi x/\lambda)}$  (in which  $\epsilon^{-j(2\pi x/\lambda)}$  expresses the change of phase with distance  $x$  measured in direction of propagation) the potential of the wire at a height  $h$  with respect to ground would be  $h G \epsilon^{-j(2\pi x/\lambda)}$  and the potential gradient along the wire would be  $\frac{d}{dx} h G \epsilon^{-j(2\pi x/\lambda)}$

$$= -j \frac{2\pi}{\lambda} h G \epsilon^{-j(2\pi x/\lambda)}$$

If the height of the wire is 10 meters and the wave length 15,000 meters the magnitude of the horizontal potential gradient would be

$$\frac{2\pi h}{\lambda} G = \frac{2\pi \times 10}{15,000} G = 0.0042G \text{ or } 0.0042 \text{ of that}$$

of the vertical gradient, which is less than Zenneck's formula gives for the horizontal potential gradient due to wave tilt. Theoretical analyses agree more-

over, that there is no electromotive force induced in a horizontal wire over a perfectly conducting earth, and therefore the space potential picture of operation is untenable.

**Experimental Directive Curve.** Fig. 56 shows a directive curve obtained experimentally. A transmitting set was operated, supplying about 5 kilowatts to a small vertical antenna, at 120 meters wave length. On a field about 600 meters from the transmitting station a system of wave antennas was erected consisting of twenty-four lines each 55 meters long and about one meter above ground, radiating from a central point like the spokes of a wheel. By joining two opposite spokes together at the center, a wave antenna was obtained 110 meters long. Using the next pair gave a similar antenna 15 deg. from the last. A ground of about 20 ohms resistance was provided at each end of

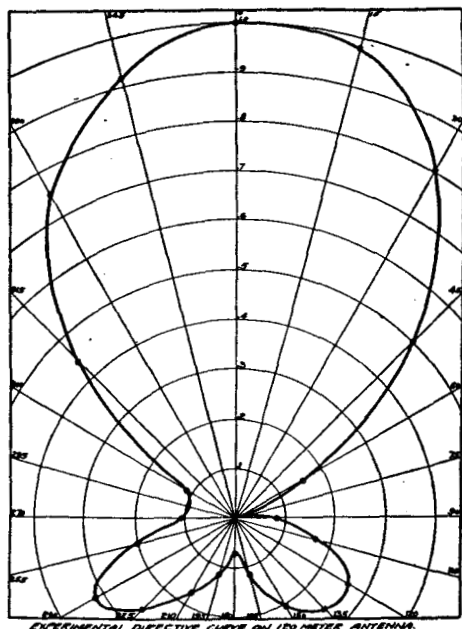

FIG. 56— $l = 110$ .  $\lambda = 120$

each antenna. The current at one end of the antenna was measured with a thermocouple and galvanometer, the opposite end being damped by a resistance. Measurements were taken successively on the several antennas, while the radiation was kept as nearly constant as possible. From the series of readings thus obtained Fig. 56 was plotted.

A number of factors was present to cause a difference between the shape of the experimental directive curve Fig. 56 and the curve A of Fig. 57 calculated by equation (22). The resistance used at the end opposite the ammeter was not the true surge impedance of the line, as determined by later measurements. The end verticals were high enough in comparison with the length of the antenna to cause currents of considerable relative magnitude, the ground was not perfectly level, and the divergence of the waves was appreciable on

account of the nearness of the sending station. Additional observations had been planned, but the work was interrupted before another directive curve could be obtained. As it stands the directive curve shown in Fig. 56 serves as a qualitative check on the theory.

During the same series of short wave tests, readings were taken to show the building up of the current in an antenna. A wire sectionalized every ten meters was used in the antenna which pointed toward the trans-

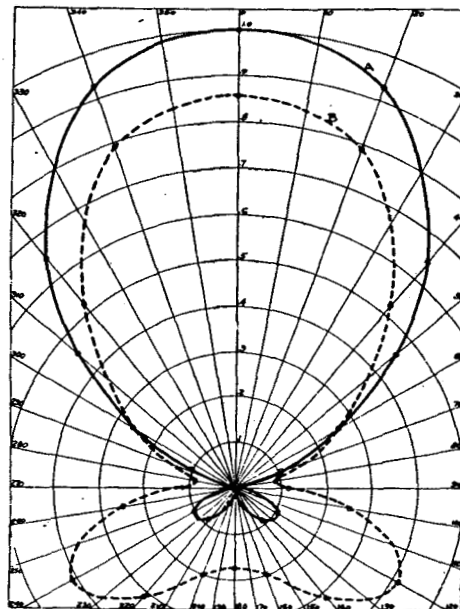

FIG. 57—CALCULATED DIRECTIVE CURVES FOR 120 METER ANTENNA. A—SIMPLE WAVE ANTENNA. B—CORRECTED FOR REFLECTIONS AND END EFFECTS.  $l = 0.12$ ,  $\lambda = 0.13$ ,  $a = 2.0$ ,  $n = 0.865$ .

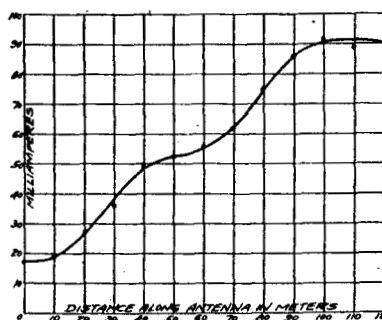

FIG. 58—OBSERVED CURRENT DISTRIBUTION IN 120 METER ANTENNA

mitting station. The line was broken successively at the sectionalizing points and the current read with the thermocouple and galvanometer. The values of current are plotted in Fig. 58. Humps such as appear in the curve might be due in part to imperfect damping, but such humps are to be expected from the theory. The total current at any point X in the antenna Fig. 26 is the resultant of the forward wave built up on the part of the antenna between A and X, and the back wave from the part between X and B.

The complete expression for the current at a point X on an antenna of length  $l$ , then becomes,

$$I_x = \frac{E_0 \cos \theta \epsilon^{-j(2\pi x \cos \theta)/\lambda}}{2Z} \times \left\{ \frac{1 - \epsilon^{-\alpha x} \epsilon^{-j \frac{2\pi x}{\lambda} (1 - n \cos \theta)}}{\alpha + j \frac{2\pi}{n\lambda} (1 - n \cos \theta)} + \frac{1 - \epsilon^{-\alpha(l-x)} \epsilon^{-j \frac{2\pi}{n\lambda} (l-x) (1 + n \cos \theta)}}{\alpha + j \frac{2\pi}{n\lambda} (1 + n \cos \theta)} \right\} \quad (35)$$

Fig. 59 shows the current distribution in an ideal antenna one wave length long, calculated by equation (35). Thus the building-up curve found by measuring the current at various points in the line, is of different form from that found by changing the length of the antenna and measuring the end currents. The latter shows a continuous increase as shown in Fig. 29.

A measurement was made in May 1921 of the intensity of the received signals on the Riverhead antenna. Mr. Weinberger of the Research Department of the

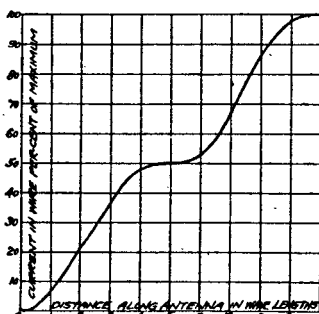

FIG. 59—CALCULATED CURRENT DISTRIBUTION IN WAVE ANTENNA

Radio Corporation, brought to Riverhead a calibrated oscillator, by which a known voltage at the desired frequency could be supplied to a circuit. By this means a voltage of signal frequency was introduced in series with the damping resistance at the north east end of the antenna, and adjusted to give as loud a tone in the receiver as the European signal which was being measured. The results of Mr. Beverage's and Mr. Weinberger's observations were, P. O. Z. Nauen, Germany, 80 millivolts; M. U. U., Carnarvon, Wales, 54 millivolts.

These correspond to about 9 and 4 microwatts respectively of received energy on the antenna.

Since the antenna is 14.5 kilometers long the voltage readings indicate a horizontal potential gradient of 5.5 millivolts per kilometer for Nauen and 3.7 millivolts per kilometer for Carnarvon. These values represent normal receiving conditions. During fading periods the signals are much weaker.

ANTENNA CONSTANTS

The electrical constants of an antenna or line which are of most immediate interest, are the wave velocity  $u$ , attenuation constant  $\alpha$ , and surge impedance  $Z$ . These may be ascertained by measuring the input impedance of the line through a sufficient range of frequency, first with the far end of the line open, and then with it short-circuited, (or grounded, if we are dealing with a ground return circuit). The ground connection must be of low resistance, for the equations

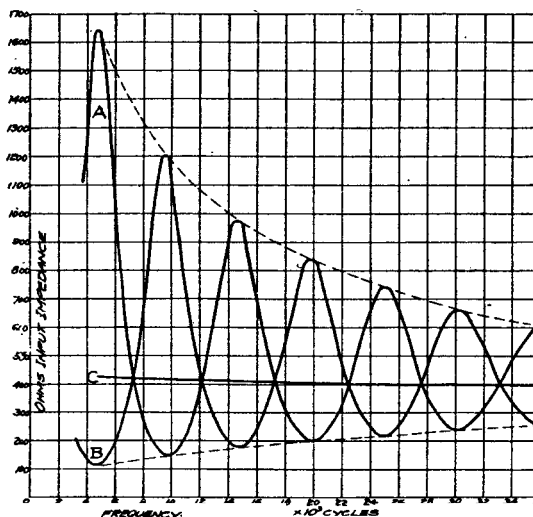

FIG. 60—INPUT IMPEDANCE OF TWELVE KILOMETER ANTENNA. A—FAR END GROUNDED. B—FAR END OPEN. C—GEOMETRICAL MEAN OF A AND B.

which follow are based on the assumption of a short-circuit reflection, and all losses will therefore be attributed to the line attenuation.

As the frequency of the current supplied to the line is varied, a series of maximum and minimum current values are observed, corresponding to standing wave conditions which cause current loops and current nodes. A current maximum corresponds to an impedance minimum and a current minimum to a maximum impedance. The impedance may be determined from

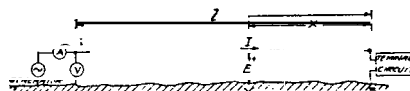

FIG. 61—REFERENCE FIGURE FOR DISCUSSION OF LINE IMPEDANCE

the supplied voltage and current or by the substitution method, which will be described. Only the maximum and minimum values of impedance are required for the present purpose.

Fig. 60 shows the input impedance of a 12-kilometer two-wire antenna as a function of frequency. A maximum input impedance when the far end is open is seen to occur at the same frequency at which the input impedance is a minimum when the far end is short-

circuited. The frequencies at which the maxima and minima occur indicate the line velocity, while the ratio of minimum to maximum impedance gives a basis for calculating the attenuation.

**Determination of Constants from Input Impedance.** Fig. 61 shows a generator (or oscillator) supplying alternating current to a line. This results in waves which travel from A to B. Assuming for the time being that there is no reflection at B and no return waves, the relation of voltage to current is  $E/I = Z$  in which Z is the surge impedance of the line. When the generator makes the point A positive with respect to ground it supplies a current in the direction A - B. Let us now imagine the generator and the absorbing terminal circuit interchanged so that the generator supplies current to the end B and the waves travel from B to A. The impedance measured at the terminals of the generator will be the same as before, but when the line is positive with respect to ground the current will be flowing in the direction B - A. Therefore if we define the voltage as positive when the line is positive with respect to ground, and the current as positive when in the direction A - B, then for waves traveling in the direction A - B the voltage is  $E = +Z I$ , but for waves traveling in the direction B - A the relation is  $E = -Z I$ .

If the forward wave leaves the end A with a magnitude and phase represented by  $I_0$  it will reach B with the magnitude and phase  $I_0 e^{-(\alpha + j\beta)l}$  or  $I_0 e^{-\gamma l}$  in which  $\gamma = \alpha + j\beta$ . We shall represent the forward wave as it reaches B by the symbol  $I_1$ . Then since  $I_1 = I_0 e^{-\gamma l}$ ,  $I_0 = I_1 / e^{-\gamma l} = I_1 e^{\gamma l}$ . Likewise at any point X, Fig. 61, x kilometers from B measured toward A, the current of the forward wave is  $I_1 e^{\gamma x}$ . And the voltage of the forward wave at X is  $Z I_1 e^{\gamma x}$ .

If the reflected wave leaves B with a magnitude and phase represented by  $I_2$ , it will be  $I_2 e^{-\gamma x}$  when it reaches X, and  $I_2 e^{-\gamma l}$  when it reaches A. And the voltage of the return wave is  $-Z I_2$  at B,  $-Z I_2 e^{-\gamma x}$  at X and  $-Z I_2 e^{-\gamma l}$  at A.

When waves traveling in both directions are present, the total current in the line at any point X will be the vector sum of the currents due to the two trains of waves or

$$I_x = I_1 e^{\gamma x} + I_2 e^{-\gamma x} \tag{36}$$

And the total voltage will be the vector sum of the voltages  $Z I_1 e^{\gamma x}$  and  $-Z I_2 e^{-\gamma x}$ , or

$$E_x = Z I_1 e^{\gamma x} - Z I_2 e^{-\gamma x} \tag{37}$$

The ratio of voltage to current, or the impedance at X is

$$E_x / I_x = Z \frac{I_1 e^{\gamma x} - I_2 e^{-\gamma x}}{I_1 e^{\gamma x} + I_2 e^{-\gamma x}} \tag{38}$$

or at A the impedance is

$$Z_A = Z \frac{I_1 e^{\gamma l} - I_2 e^{-\gamma l}}{I_1 e^{\gamma l} + I_2 e^{-\gamma l}} \tag{39}$$

This becomes equal to Z if  $I_2 = 0$ , and becomes  $-Z$  if  $I_1 = 0$ . The negative sign means that power is being supplied from the line to the terminal circuit by waves which travel in the direction B - A, instead of from the terminal circuit to the line as is the case for waves leaving A. If the waves leaving A are larger than those arriving at A (i. e. if  $I_1 e^{\gamma l} > I_2 e^{-\gamma l}$ ) there is a net power supply to the line.

If the line is made very short  $Z_0$ , the impedance at A, of the line plus the terminal circuit, must eventually become equal to that of the terminal circuit alone or equal to  $Z_0$ . Setting  $l = 0$  in (39) and equating to  $Z_0$ , we have

$$Z_A \text{ (for } l = 0) = Z \frac{I_1 - I_2}{I_1 + I_2} = Z_0 \tag{40}$$

The value of  $Z_0$  relative to Z determines the relation of the reflected wave  $I_2$  to the oncoming wave  $I_1$  at the reflection point B. From (40)

$$\frac{I_1 - I_2}{I_1 + I_2} = Z_0 / Z \tag{41}$$

Adding 1 to each side of this equation,

$$\frac{2 I_1}{I_1 + I_2} = 1 + Z_0 / Z \tag{42}$$

Subtracting 1 from each side of (41)

$$\frac{-2 I_2}{I_1 + I_2} = Z_0 / Z - 1 \text{ or } \frac{2 I_2}{I_1 + I_2} = 1 - Z_0 / Z \tag{43}$$

From 42 and 43

$$I_2 / I_1 = \frac{1 - Z_0 / Z}{1 + Z_0 / Z} \tag{44}$$

This is the general vector expression for reflection, which was given on page 56, where an illustrative problem was worked. We have used the term "reflection coefficient" for the ratio  $I_2 / I_1$ .

If the line is short circuited at the end,  $Z_0 = 0$  and (44) becomes  $I_2 / I_1 = 1$  or  $I_2 = I_1$ . The total current  $I_1 + I_2$  then becomes  $2 I_1$  which is the familiar case of the current doubling at a short-circuit reflection.

If  $Z_0 = Z$ ,  $I_2 / I_1 = 0$ , or  $I_2 = 0$  or there is no reflection.

With an open circuit at the end  $Z_0 = \infty$ ,  $I_2 / I_1$  becomes  $-1$ , or  $I_2 = -I_1$ , the total current at the reflection point being  $I_1 + I_2 = I_1 - I_1 = 0$ . The total voltage at the reflection point becomes  $Z (I_1 - I_2) = Z (I_1 + I_1) = 2 Z I_1$  or twice that due to the oncoming wave alone. This is the case of doubling of voltage at an open circuit reflection.

Fig. 62 shows the current and voltage vectors at 0, 1, 2, 3, 4, 5 and 6 kilometers from a short-circuit reflection, the attenuation constant being taken as 0.05 per kilometer, the wave length 15 kilometers and the velocity ratio  $n = 0.8$  so that the length of a wave on the wire is 12 kilometers. Since in the case of a short circuit reflection  $I_2 = I_1$ , their vectors coincide at the reflection point. The vector  $I_1 e^{\gamma x}$  of the forward wave, is advanced in phase and increased in magnitude as we proceed toward the source, or away



from the reflection point, while the vector of the reflected wave,  $I_2 e^{-\gamma x}$ , becomes smaller and retarded in phase. At 3 kilometers from the reflection end, the current vectors have rotated 90 deg. each, in opposite directions, and are therefore 180 deg. apart, and the resultant current is seen to have a minimum value equal to the difference in the lengths of the two vectors. Referring next to the voltage diagram, the vectors  $Z I_1$  and  $-Z I_2$  at the reflection point are equal and opposite giving zero resultant, for there is no voltage across the line at the short circuit. At 3 kilo-

numerator and denominator by  $e^{-\gamma x}$ , which simplifies the expression, we get

$$E_x/I_x = Z \frac{I_1 - I_1 e^{-2\gamma x}}{I_1 + I_1 e^{-2\gamma x}} = Z \frac{1 - e^{-2\gamma x}}{1 + e^{-2\gamma x}} \tag{45}$$

$$= Z \frac{1 - e^{-2\alpha x} e^{-j2\beta x}}{1 + e^{-2\alpha x} e^{-j2\beta x}}$$

which is the impedance of the line  $x$  kilometers from a short circuit reflection

In the case we have been considering  $x = 3$  kilometers and the wire wave length  $= n\lambda = 12$  kilo-

meters, so that  $x = \frac{1}{4} n\lambda$ . Since  $\beta = \frac{2\pi}{n\lambda}$ ,  $\beta x =$

$= \frac{2\pi}{n\lambda} \times \frac{n\lambda}{4} = \pi/2$ , and  $2\beta x = \pi$ . The factor

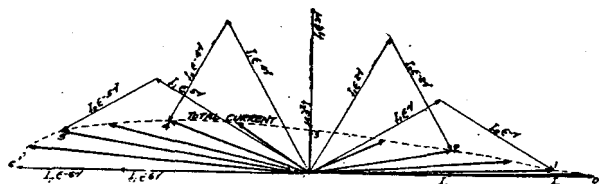

FIG. 62A—CURRENTS AT VARIOUS DISTANCES FROM SHORT CIRCUIT (HEAVY ARROWS ARE VECTORS OF TOTAL CURRENT)

meters from the short circuit the voltage vectors have rotated into coincidence, giving a maximum resultant equal to the sum of the lengths of the two vectors. Since the current reaches a minimum and the voltage a maximum value at this point, the impedance or ratio of voltage to current will be a maximum. Fig. 63 shows the total current and voltage at various distances from the short-circuited end, calculated by vectors as indicated in Fig. 62. The impedance and phase angle are also shown. The general form of the current distribution curve should be compared with the experimental curves shown in Figs. 7 to 9.

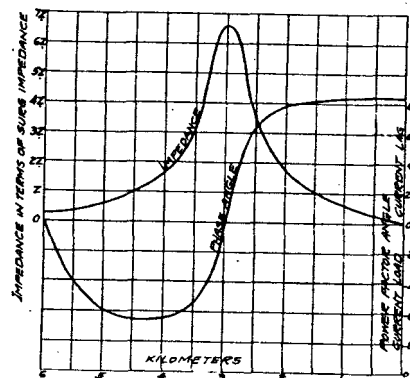
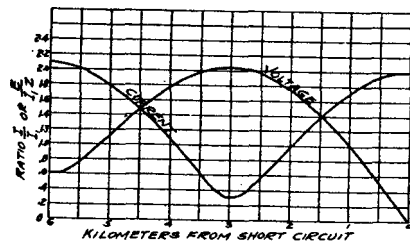

FIG. 63—CURRENT, VOLTAGE, IMPEDANCE AND POWER FACTOR ANGLE ON SHORT-CIRCUITED LINE. (CURRENT AND VOLTAGE EXPRESSED AS RATIO TO THOSE OF WAVE REACHING REFLECTION POINT)

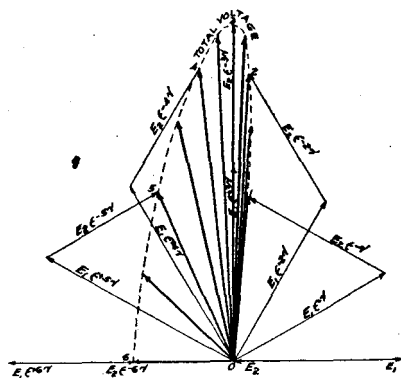

FIG. 62B—VOLTAGE AT VARIOUS DISTANCES FROM SHORT CIRCUIT (HEAVY ARROWS ARE VECTORS OF TOTAL VOLTAGE)

The three kilometers, or distance at which the impedance minimum was reached in Fig. 62, is a quarter of the length of a wave on the wire. Let us compare this result with that given by equation (38). Restating the equation.

$$E_x/I_x = Z \frac{I_1 e^{\gamma x} - I_2 e^{-\gamma x}}{I_1 e^{\gamma x} + I_2 e^{-\gamma x}} \tag{38}$$

In the case of a short-circuit reflection  $I_2 = I_1$ . Making this substitution in (38) and multiplying

$e^{-j2\beta x}$  in (45) then becomes  $e^{-j\pi} = \cos \pi - j \sin \pi = -1$  so that the impedance a quarter of a wire wave length from a short-circuit reflection is

$$Z_{min} = Z \frac{1 + e^{-2\alpha x}}{1 - e^{-2\alpha x}} \tag{46}$$

At six kilometers or a half wire wave length from the short-circuit reflection, we find in Fig. 62 that the total voltage is a minimum and the total current a maximum, so that the line impedance is at a minimum value.

Here  $x = \frac{1}{2} n\lambda$ ,  $\beta x = \frac{2\pi}{n\lambda} \times \frac{n\lambda}{2} = \pi$ , and  $2\beta x = 2\pi$ . Therefore  $e^{-j2\beta x} = e^{-j2\pi} = +1$ . Using

this in (45) we find that the impedance a half wire wave length from a short-circuit reflection is

$$Z_{min} = Z \frac{1 - \epsilon^{-2\alpha x}}{1 + \epsilon^{-2\alpha x}} \tag{47}$$

The factor  $\epsilon^{-j2\beta x}$  again reaches the value  $-1$ , when  $2\beta x$  becomes  $3\pi, 5\pi, 7\pi, 9\pi, \dots$  or when the distance  $x$  is equal to any odd number of quarter wave lengths, and it becomes  $+1$  when  $2\beta x$  equals  $2\pi, 4\pi, 6\pi, 8\pi, \dots$  or when  $x$  is an even number of quarter wave lengths. Therefore the impedance of a short-circuited line is expressed by (46) if  $x$  is an odd number of quarter wave lengths and by (47) if  $x$  is an even number of quarter wave lengths. (It being understood that "wave length" in this connection refers to the Wire wave length,  $n\lambda$ )

In the case of an open-circuit reflection  $I_2 = -I_1$ , and the general expression (38) for impedance becomes

$$\begin{aligned} E_x/I_x &= Z \frac{I_1 \epsilon^{\gamma x} - I_2 \epsilon^{-\gamma x}}{I_1 \epsilon^{\gamma x} + I_2 \epsilon^{-\gamma x}} = Z \frac{I_1 \epsilon^{\gamma x} + I_1 \epsilon^{-\gamma x}}{I_1 \epsilon^{\gamma x} - I_1 \epsilon^{-\gamma x}} \\ &= Z \frac{1 + \epsilon^{-2\gamma x}}{1 - \epsilon^{-2\gamma x}} = Z \frac{1 + \epsilon^{-2\alpha x} \epsilon^{-j2\beta x}}{1 - \epsilon^{-2\alpha x} \epsilon^{-j2\beta x}} \end{aligned} \tag{48}$$

In Fig. 62 the minimum current or voltage is seen to be the difference between the lengths of the vectors of the forward and return waves. If these are very nearly equal, the impedance becomes very high at a

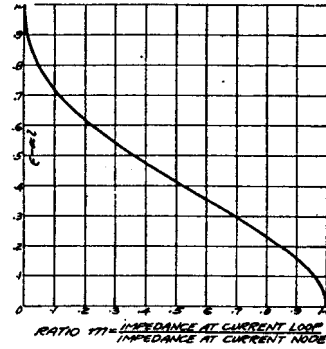

FIG. 64—CURVE FOR DETERMINING LINE ATTENUATION FROM IMPEDANCE RATIO

current node, and very low at a voltage node. On the other hand if the return wave is small compared with the forward wave, the impedance varies through a much smaller range. Thus the ratio of minimum to maximum impedance shows the magnitude of the return

TABLE VIII  
CONDITIONS FOR MAXIMUM OR MINIMUM IMPEDANCE OF LINE

Distance from point of reflection, wave lengths.....	1/4	2/4	3/4	4/4	5/4	6/4	7/4	8/4	9/4
Impedance, with short-circuit reflection.....	max.	min.	max.	min.	max.	min.	max.	min.	max.
Impedance, with open circuit reflection.....	min.	max.	min.	max.	min.	max.	min.	max.	min.

When  $\epsilon^{-j2\beta x} = -1$ , or when  $x$  is an odd number of quarter wave lengths, the impedance (48) takes the minimum value shown in (47), and when  $\epsilon^{-j2\beta x} = +1$  or  $x$  is an even number of quarter wave lengths the impedance  $x$  kilometers from the end of the open-circuited line has the maximum value given by (46).

Summarizing, the impedance of the line takes the minimum value (47) or the maximum value (46), depending on the type of reflection and the distance from the reflection point, as shown in Table VIII. Since in the present case the impedance is to be measured at the end of the line we substitute  $l$  for  $x$  in (46) and (47) giving for the line input impedance.

$$Z_{max} = Z \frac{1 + \epsilon^{-2\alpha l}}{1 - \epsilon^{-2\alpha l}} \tag{46a}$$

$$Z_{min} = Z \frac{1 - \epsilon^{-2\alpha l}}{1 + \epsilon^{-2\alpha l}} \tag{47a}$$

In the foregoing discussion we have thought of the wave length as constant and the distance from the point of reflection as being varied, but a series of maxima and minima as indicated in Table VIII is also obtained if the length of the line is constant and the wave length, or frequency is changed. This is what is done when we take the measurements for plotting the input impedance curve like that shown in Fig. 60.

wave as compared with the forward wave, or in other words it shows the attenuation which the waves undergo in traveling to the end of the line and back.

If the frequency of the current being supplied to the line, (in Fig. 61) is such that there are a whole number of quarter waves on the line, and we take measurements of the input impedance, with the far end open, and also with it short-circuited, we obtain a maximum impedance (46a) and a minimum impedance (47a) for the same frequency. Letting  $m$  stand for the ratio of the minimum to maximum impedance, we may calculate the attenuation as follows:

$$\begin{aligned} m &= Z_{min}/Z_{max} = \frac{Z \frac{1 - \epsilon^{-2\alpha l}}{1 + \epsilon^{-2\alpha l}}}{Z \frac{1 + \epsilon^{-2\alpha l}}{1 - \epsilon^{-2\alpha l}}} \\ &= \left( \frac{1 - \epsilon^{-2\alpha l}}{1 + \epsilon^{-2\alpha l}} \right)^2 \\ \sqrt{m} &= \frac{1 - \epsilon^{-2\alpha l}}{1 + \epsilon^{-2\alpha l}} \\ \sqrt{m} + 1 &= \frac{2}{1 + \epsilon^{-2\alpha l}} \end{aligned} \tag{49}$$

$$\sqrt{m} - 1 = \frac{2\epsilon^{-2\alpha l}}{1 + \epsilon^{-2\alpha l}} \text{ or}$$

$$1 - \sqrt{m} = \frac{2\epsilon^{-2\alpha l}}{1 + \epsilon^{-2\alpha l}}$$

$$\frac{1 - \sqrt{m}}{1 + \sqrt{m}} = \epsilon^{-2\alpha l}$$

$$\sqrt{\frac{1 - \sqrt{m}}{1 + \sqrt{m}}} = \epsilon^{-\alpha l} \quad (50)$$

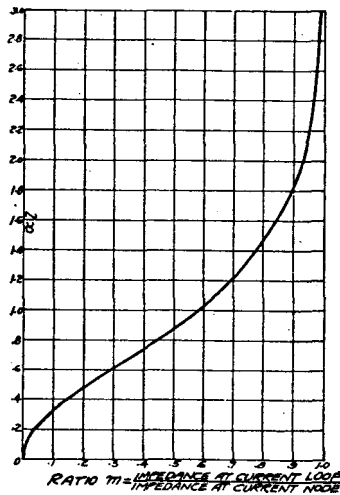

FIG. 65—CURVE FOR DETERMINING ATTENUATION CONSTANT

Fig. 64 shows  $\epsilon^{-\alpha l}$  as a function of the impedance ratio  $m$ , and Fig. 65 shows  $a$  as a function of  $m$ .

If the frequency at which it is desired to determine the attenuation, is not such as to make the line an exact number of quarter waves long, the values of maximum and minimum impedance may be found by interpolation, using the envelopes of the curves as shown in Fig. 60. For example, in Fig. 60 the imped-

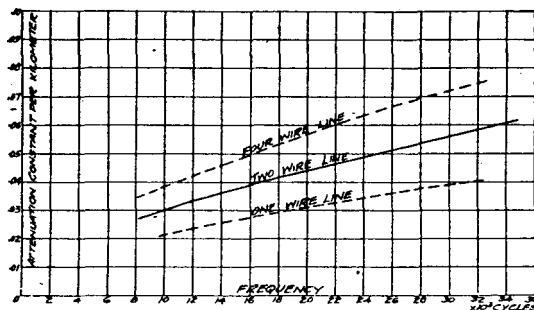

FIG. 66—ATTENUATION CONSTANTS OF ANTENNAS

ance ratio at 25,000 cycles is  $m = 220/740 = 0.297$ . Using this in Fig. 64 we find  $\epsilon^{-\alpha l} = 0.54$ .

Then  $-a l = \log_e 0.54$  and  $+ \alpha l = \log_e \frac{1}{.54} = \log_e 1.85$

$1.85 = 2.3 \log_{10} 1.85 = 2.3 \times 0.2672 = 0.617$  which may also be found directly from Fig. 65.

In this case  $l = 12$  kilometers so that  $a = 0.617/12$

$= 0.0513$  Fig. 66 shows the values of the attenuation constant  $\alpha$ , corresponding to the input impedance curves shown in Fig. 60.

Referring again to equations (46) and (47) we see that if we multiply the two together we have  $(Z_{max.})(Z_{min.}) = Z^2$  or

$$Z = \sqrt{(Z_{max.})(Z_{min.})} \quad (51)$$

Using the values of impedance for 25,000 cycles obtained from Fig. 60 we find that the surge impedance of the line at this frequency is  $Z = \sqrt{740 \times 220} = 435$  ohms. The surge impedance or geometrical mean of the maximum and minimum impedance values is indicated in curve C of Fig. 60.

For finding the line velocity it is necessary to know the mode of oscillation (or number of quarter waves on the line) for each frequency at which a maximum or minimum impedance occurs. A curve like the one marked A in Fig. 67 can then be plotted showing the number of quarter waves on the line, as a function of frequency. A similar curve B is plotted on the same sheet for a light velocity line of the same length. Thus if the length of the line is 12 kilometers and its wave

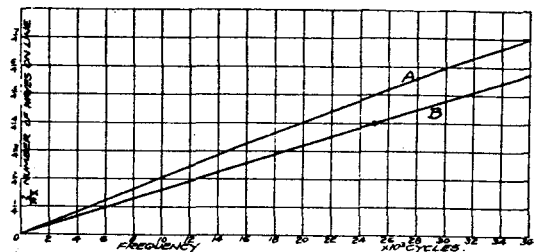

FIG. 67—MODE OF OSCILLATION OF TWELVE KILOMETER ANTENNA. A—ACTUAL LINE. B—IDEAL LINE

velocity were equal to that of light, it would show a 4/4 wave oscillation at  $\lambda = 12$ , or  $f = \frac{3 \times 10^5}{12}$  = 25,000 cycles.

Since the line B is straight and passes through the origin, it may be drawn by calculating and plotting a single point. The ordinate to the line B is  $l/\lambda$  and the ordinate to curve A is  $l/n\lambda$ , whence the velocity ratio for any frequency is

$$n = \frac{\text{Ordinate to B}}{\text{Ordinate to A}}$$

Fig. 68 shows the velocity ratio  $u/v$  or  $n$  corresponding to the input impedance curves of Fig. 60. The values shown represent a fair average of those so far observed on antennas consisting of two bare 0.102 inch (0.26cm.) diameter wires in multiple, seven to nine meters above ground. Curves are also shown which give an idea of the effect of using a different number of wires. The line constants depend not only on the type of construction but on the character and moisture of the soil and therefore will vary from place to place and change somewhat with the season.

fig. 69 shows the apparatus which the writers have used for measuring line input impedance. At either a voltage or current node the line is substantially a unity power factor load and its impedance may be determined by finding the non-inductive resistance which will give the same current. The pick-up coil should preferably have a low reactance compared with the impedance to be measured. When a current maximum is observed, the resistance is substituted for the line and the condenser  $C_2$  adjusted to tune out the reactance of the pick-up coil. The circuit is then switched back to the line and the oscillator frequency readjusted to give current maximum. If the change of oscillator frequency has been considerable a repetition of the process will be needed. In the case of a low loss line it is desirable to use a relatively high-reactance pick up coil and high sensitivity meter for measuring the impedance maxima and a lower impedance coil

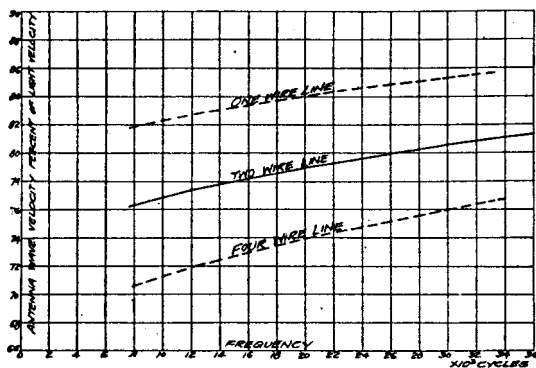

FIG. 68—WAVE VELOCITIES OF ANTENNAS

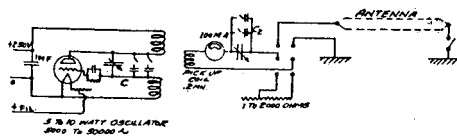

FIG. 69—CIRCUIT FOR MEASURING ANTENNA INPUT IMPEDANCE FOR LONG WAVES

and less sensitive meter for measuring the low values of line impedance. Fig. 70 shows such an arrangement, indicating coil values which have been found suitable for a 10,000 to 20,000 meter range of wave lengths. Current transformers are permissible. Owing to the rapid change from low to high-current values precautions should be taken to avoid meter burn outs. Oscillator harmonics should be minimized by using large capacity  $C$ , and high-efficiency, low-inductance coils in the oscillator circuit, with loose coupling to the pick up coil.

It is not in all cases necessary to take the impedance characteristics of the line, both open and short-circuited. With a good set of readings for either condition, the envelope of the curves can be drawn in and the surge impedance and attenuation determined approximately.

It is not necessary to use a damping resistance at the oscillator end of the line with a view to preventing

reflection. For a given frequency the line presents a definite impedance at its terminals, and adding resistance in the supply circuit merely reduces the current and voltage supplied to the line without altering the ratio of voltage to current at the line terminals.

It is desirable in some cases to check the values of line constants as determined from the input impedance, by direct measurement. Arrangement is made for telephone communication over the line as shown in Fig. 71 the circuits being designed to have negligible effect on the radio frequency currents. Various resistances are tried at the far end of the line, until a value is found which gives constant impedance at the oscillator end,

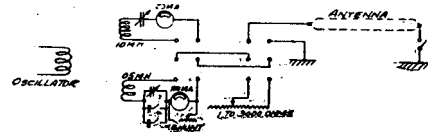

FIG. 70—CIRCUIT FOR MEASURING INPUT IMPEDANCE OF LOW LOSS LINES

over a considerable range of frequency. A small amount of reactance in addition to the resistance may be required to give perfectly constant impedance at the oscillator end, since the surge impedance is not necessarily a pure resistance. If the surge impedance changes with frequency a new resistance setting will be required for a different frequency range. Leaving the surge impedance as found in this way, in the far end of the line, simultaneous readings of the currents at the two ends are taken at a number of different frequencies, and the average ratio of received to supplied current gives the attenuation,  $e^{-\alpha l}$ . Measurements at different frequencies of the impedance of the line at the oscillator end give a check on the surge impedance as found by trial at the far end. The presence of partial reflections

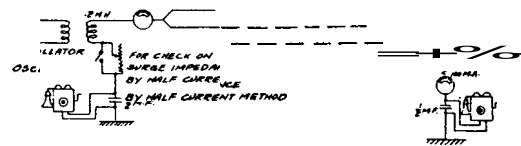

FIG. 71—CIRCUIT FOR DIRECT MEASUREMENT OF ATTENUATION

on the line, which may result from changes in ground conditions, may cause considerable error in the values of the constants as found by this method.

More complete and reliable information on the behavior of the line is obtained by supplying one end with current of constant frequency and amplitude, and measuring the current at intervals along the line, with different circuit conditions at the far end. If the end is damped with the true surge impedance, and there are no points of partial reflection on the line itself, the current will show a continuous decrease, following the exponential law. If the current is plotted as a function of distance on "semi log" paper, the points will fall on a straight line and the slope of the line will show the

attenuation constant. If reflections occur either at the end or at any other point on the line there will be humps or hollows in the curve. With the end open-circuited or grounded, this method of study shows the standing waves on the line, from which the velocity and attenuation can be calculated. Curves of this kind are shown in Figs. 3; 4, 5, 7, 8 and 9.

**Interpretation of Observed Line Constants.** The explanation of the manner in which velocity and attenuation are affected by frequency, is to be found in the varying depth of penetration of the return currents into the ground; Fig. 72 shows the general shape of the path of the ground current. There is a "skin effect" which tends to concentrate the earth currents near the surface. If it were not for this skin effect the mean depth of the earth currents in ground of uniform conductivity would be a considerable fraction of a wave length, probably between one and two thousand meters with a twelve thousand meter wave. As it is, most of the earth current is within one hundred meters of the surface, with waves of this length and soil of moderate conductivity. Zenneck's<sup>19</sup> analysis gives the depths of penetration of earth currents for the case of space waves of plane wave front from which we can obtain a rough idea of the order of magnitude for the case of waves on a wire supported a short distance above earth.

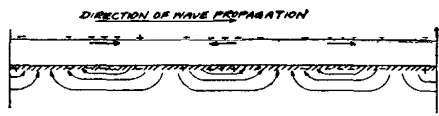

FIG. 72—DISTRIBUTION OF GROUND CURRENTS UNDER WIRE CARRYING WAVES

If the earth carries current almost entirely by conduction rather than by capacity, which is true for all except short wave lengths or extremely high-resistance ground, Zenneck's formula for penetration may be stated in the following form.

$$D = 50 \sqrt{\rho/f}$$

in which  $D$  is the depth in meters at which the earth current density is reduced to  $1/\epsilon = 0.368$  of its value at the surface.

$\rho$  = specific resistance of the earth in ohms per centimeter cube.

$f$  = frequency

This gives for a 12,000 meter wave ( $f = 25,000$ ) and a specific resistance  $\rho = 10^5$  ohms, a penetration  $D = 100$  meters.

In Fig. 72 it is seen that there are both vertical and horizontal earth currents, but for the vertical currents the distance is relatively small and the cross section great. If the drawing were more nearly to scale this difference between the vertical and horizontal earth currents would be still more apparent. The conditions may be approximately represented by Fig. 73 in which a

19. Translation given in Fleming "Principles of Electric Wave Telegraphy and Telephony" Third Edition P. 812.

small resistance is shown in series with the line to ground capacity and a higher resistance in the horizontal return conductor, which is at a depth corresponding to the mean depth of the earth currents. The capacity of such a line would be substantially the same as for a wire of the same height, over a perfectly conducting earth. The inductance would be that corresponding to a wire  $H + D$  meters above a conducting plane which forms the return conductor. There would be a small added charging current loss due to the resistance in series with the capacity and a much larger loss due to the resistance of the horizontal return conductor. Since the depth of penetration increases with wave length we should expect greater inductance and therefore lower velocities on long waves. The greater the penetration the lower the resistance to the earth currents. Therefore the losses are less and the attenuation less on long waves. High-ground resistance increases the penetration and loss at the same time, and therefore reduces the velocity and increases the attenuation.

Beverage found for the sandy soil near Eastport, L. I. a specific resistance of about  $2 \times 10^6$  ohms per centimeter cube. Since ground water occurs at a depth of something less than 100 feet (30 meters) the excess resistance and inductance of the Riverhead antenna are materially less than those corresponding to this value of soil resistance.

Table IX shows the calculated inductance and capacity of a one, two, and a four wire line based on perfectly conducting ground. The wire spacing is taken as 4 feet (1.3 meters) each way with 20 feet (6.6 meters) clear above ground.

TABLE IX. CONSTANTS OF LINE OVER PERFECT GROUND

	1 wire	2 wires	4 wires
$L_0$ inductance, $\frac{m h}{k m}$ , perfect ground.....	1.86	1.14	0.8
$C_0$ capacity, $\frac{m f}{k m}$ , perfect ground.....	0.006	0.0098	0.0139
D-C. resistance of wires, $\frac{\text{ohms}}{km}$ .....	3.3	1.64	0.82
$R_w = A-C$ . <sup>20</sup> resistance of wires			
at $f = 12,000 \sim$ .....	4.44	2.22	1.11
20,000.....	5.50	2.75	1.38
30,000.....	6.6	3.3	1.64

The observed attenuation and velocity shown in Figs. 66 and 61, give a basis for calculating the effective inductance and resistance provided the capacity is known. The actual capacity is somewhat greater than  $C_0$  as given above owing to insulators, poles, and the proximity of trees. An audio-frequency bridge measurement showed 0.011 microfarads per kilometer for two wires at a height of thirty feet. As this value seems

20. Calculated by formula for skin effect given on page 135 of Principles of Electric Wave Telegraphy and Telephony, J. A. Fleming, 1916.

high and the accuracy of the bridge was not checked, we shall assume the capacity to be 10 per cent greater than the calculated value  $C_0$ . This gives the constants shown in Table X for a two wire line.

TABLE X.

	Two Wire Line		
	12,000	20,000	30,000
Frequency.....	12,000	20,000	30,000
$u$ = observed velocity, km. per sec. ....	$2.33 \times 10^8$	$2.37 \times 10^8$	$2.42 \times 10^8$
$n = \frac{u}{3 \times 10^{10}}$ = velocity ratio.....	77.4	79	80.6
$L = \frac{1}{u^2 (1.1 C_0)}$ = effective inductance....	1.73	1.66	1.69
$L_0 = L + L_0$ = added inductance for ground, mh. per km. ....	0.59	0.52	0.45
$D$ = mean depth of earth currents (meters), ..	118	82	56
$Z = \sqrt{\frac{L}{1.1 C_0}}$ surge impedance.....	400	393	384
$a$ = observed attenuation per kilometer. ....	0.033	0.044	0.066
$R = 2 a Z$ = resistance to give observed attenuation, ohms per k. m. ....	26.5	34.5	43
$R_j = R - R_w$ = equivalent resistance of ground.....	24.3	31.75	39.7
$\omega L$ = inductive reactance per kilometer. ....	131	208	300

The ground losses and penetration would not be materially different for the one and four wire lines. Taking the values of  $R_0$  and  $L_0$  for the two wire line as applicable to the one and four wire lines, we may calculate the attenuation and velocity to be expected on the latter as follows:

$$\text{The formulas } Z = \sqrt{L/C}, a = \frac{R}{2Z}, \text{ and } u = \frac{i}{\sqrt{LC}}$$

are approximations applicable when the resistance is small compared with the inductive reactance. In this

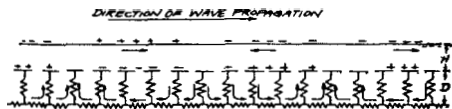

FIG. 73—CIRCUIT APPROXIMATELY EQUIVALENT TO GROUND

instance  $\omega L$  is more than four times  $R$  for all the cases calculated and the errors in the magnitudes of  $a, u$ , and  $Z$ , due to the use of these abbreviated formulas are small. There is however an appreciable phase angle to the vector of the surge impedance  $Z$ , which it is of interest to estimate. If the losses were equally divided between dielectric and vertical ground current losses on the one hand and wire resistance and horizontal ground current losses on the other, or to put it differently if a short section of line with ground return had the same power factor, considered as an inductance as it has when treated as a condenser, then the surge impedance, would have zero phase angle or be equivalent to a pure resistance. In the present case the ground losses are for the most part equivalent to the effect of an added resistance in the line. If we assume all the losses to be the result of line resistance we shall obtain a maximum value for the phase angle of the surge

impedance. The full expression for surge impedance in vector terms is

$$Z = \sqrt{\frac{R + j \omega L}{G + j \omega C}}$$

in which  $G$  represents a shunt conductance of such value as to give the equivalent of all the dielectric loss.

The phase angle of  $Z$  is  $1/2 \left( \tan^{-1} \frac{\omega L}{R} - \tan^{-1} \frac{\omega C}{G} \right)$

which becomes  $-1/2 \tan^{-1} \frac{R}{\omega L}$  when  $G = 0$ . From

the values of  $L, C$ , and  $R$  given in the above tables we find the values for the surge impedance shown in Table XII. The figures preceded by  $-j$  are ohms of capacity reactance. The actual amount of reactance would be slightly less than this, since  $G$  is not actually zero.

### DIRECTIVE RECEPTION AND STRAY RATIO

*Direction of Static.* The general opinion that, on the average, summer static comes from a definite direction, for example from a southwesterly direction on our North Atlantic coast, seems to have been brought to a focus by Pickard's classical paper<sup>21</sup> on "Static Elimination by Directional Reception." In the discussion Pickard cites an interesting note made by Marconi in 1906, giving the results of his observation on the directivity of static.

The remarks by Austin, Blatterman, Hoxie and Beverage are of particular interest in showing the trend of opinion as based on observation. The early work of Taylor<sup>22</sup> is also of considerable interest in this connection. Taylor found that atmospheric waves were very strong on the high vertical antennas contemplated for European reception. After describing tests of various heights and lengths of antenna with the result that the signal to static ratio remained constant, he goes on to say—"One of the first questions that naturally arises in connection with these disturbances is, 'where do they come from?' and it was considered that if their office of origin could be located this might help solve the problem of their elimination. For this purpose an investigation has been conducted at the Belmar Station, where a directive antenna of the Bellini-Tosi type was erected." The conclusions from his observations are that static at Belmar has an average direction of south to southwest, as later observations have shown. Alexanderson<sup>23</sup> had also observed the marked directivity of static with his Barrage Receiver. More recently a great deal of very valuable systematic experimental work has been done by Austin<sup>24</sup> on this subject.

21. Institute of Radio Engineers 1920 Vol. 8, P. 397.
22. C. H. Taylor, Direction of Maximum Atmospheric Disturbances on Wave Range 6000 to 12000 Meters "Belmar," N. J. Sept., Oct. 1915 and Nov., Jan. 1916, Yearbook of Wireless Telegraphy and Telephony 1917 P. 726-743.
23. E. F. W. Alexanderson, I. R. E. Aug. 1919.
24. Louis Austin Jour. Franklin Inst. May 1921, page 619.

	One Wire Line			Four Wire Line		
	12,000	20,000	30,000	12,000	20,000	30,000
Frequency.....	12,000	20,000	30,000	12,000	20,000	30,000
$L_0$ - inductance, perfect ground, mh. per km.....	1.86	1.86	1.86	0.8	0.8	0.8
$L_p$ - inductance due to penetration.....	0.59	0.52	0.45	0.59	0.52	0.45
$L = L_0 + L_p =$ total inductance.....	2.45	2.38	2.31	1.39	1.32	1.25
$C = 1.1 C_0 =$ Capacity.....	0.0066	0.0066	0.0066	0.0153	0.0153	0.0153
$u = \frac{1}{\sqrt{LC}}$ = velocity.....	$2.48 \times 10^5$	$2.62 \times 10^5$	$2.56 \times 10^5$	$2.16 \times 10^5$	$2.22 \times 10^5$	$2.28 \times 10^5$
$n = \frac{u}{3 \times 10^{10}}$ = velocity ratio.....	0.827	0.84	0.853	0.72	0.74	0.76
$R_g =$ ground resistance. $\frac{\text{ohms}}{\text{km}}$ .....	24.3	31.75	39.7	14.3	11.75	39.7
$R_w =$ wire resistance $\frac{\text{ohms}}{\text{km}}$ .....	4.4	5.5	6.6	1.1	1.4	1.6
$R = R_g + R_w =$ total resistance.....	28.7	37.25	46.3	15.4	13.15	41.3
$a = \frac{R}{2Z}$ = attenuation constant.....	0.0235	0.031	0.039	0.042	0.0565	0.072
$Z = \sqrt{L/C}$ = surge impedance.....	610	602	592	301	294	286
$\omega L =$ inductive reactance per km.....	185	299	435	105	166	236

TABLE XII

	1 Wire Line			2 Wire Line			4 Wire Line		
	12,000	20,000	30,000	12,000	20,000	30,000	12,000	20,000	30,000
Frequency.....	12,000	20,000	30,000	12,000	20,000	30,000	12,000	20,000	30,000
$\omega L$ .....	185	299	435	131	208	300	105	166	236
$R$ .....	28.7	37.2	46.3	26.5	34.5	43	25.4	33.1	41.3
$\tan^{-1} \frac{R}{\omega L}$ .....	8.8°	7.0°	6.0°	11.4°	9.4°	8.20	13.6°	11.3°	10°
Angle of $Z = -1/2 \tan^{-1} \frac{R}{\omega L}$ .....	-4.4°	-3.5°	-3.0°	-5.70	-4.70	-4.10	-6.8°	-5.65°	-5°
$Z =$ Total Impedance.....	610	602	592	400	393	384	301	294	286
Components. $R$ .....	608	591	571	398	392	384	299	292	285
$X$ .....	-47j	-61j	-31j	-40j	-32j	-32j	-36j	-29j	-25j

Austin's conclusions on the directivity of static for the wave length range of 8000 to 18,000 meters are briefly as follows:

1. U. S. Atlantic Coast static mainly southwest.
2. Gulf Coast roughly southwest.
3. Seattle (vicinity) roughly east.
4. San Francisco and San Diego sharply east.
5. Porto Rico two marked directions, namely, west and south.

**Gain from Directive Receivers.** Even at times when static shows no marked predominating direction, a directive receiving system will obviously reduce or eliminate that fraction of the static which comes from directions to which the receiving system is insensitive. When static is sharply directional the possibilities of improving the stray ratio through the use of a suitable directive receiving system are still greater.

An important step in the improvement of stray ratios was taken when loops superseded static antennas for long wave reception. A further improvement resulted from combining a loop with a static antenna to give a unidirectional antenna system. The loop is more directive than the static antenna. Fig. 74 shows the directive curve of a loop, the large circle being drawn to show the relative sensitiveness of a static antenna for

various directions as compared with the loop. The area of the directive curve of the loop is one-half that of the static antenna when both have the same sensitiveness for signal. This means that if disturbances come equally from all directions, the loop will receive just half the energy from the disturbing waves which the static antenna receives.

The combination of loop and static antenna while no more sharply directive than the simple loop from the standpoint of the area of its directive curve, can be adjusted so that reception from certain directions is prevented. Fig. 75 shows the directive curve of the combination of loop and static antenna when the intensities of the two are adjusted to equality for signal. By using less energy from the static antenna than from the loop the directive curve can be made to assume any form such as Fig. 76, intermediate between the cardioid of Fig. 75 and the lemniscate of Fig. 74. This is an exceedingly useful property, particularly if static or other disturbances comes largely from a certain direction.

At times static has a predominating direction, while at other times it appears to be widely distributed, so that both features are important—directive curve of small area, and ability to prevent reception entirely

from certain directions. If static, while not confined to a specific direction, comes largely from a certain quarter, it is important to have an antenna system whose directive curve has a small area within the angle from which the heaviest static comes.

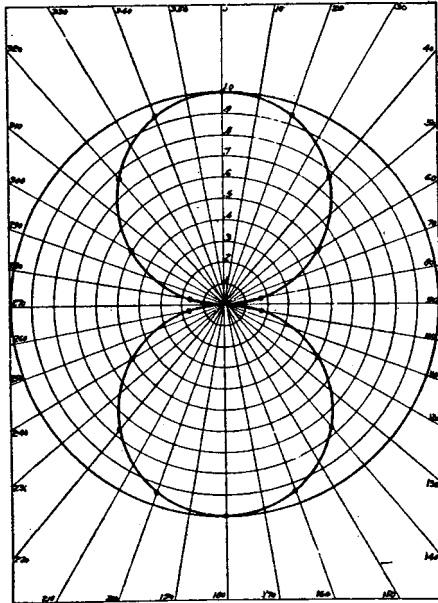
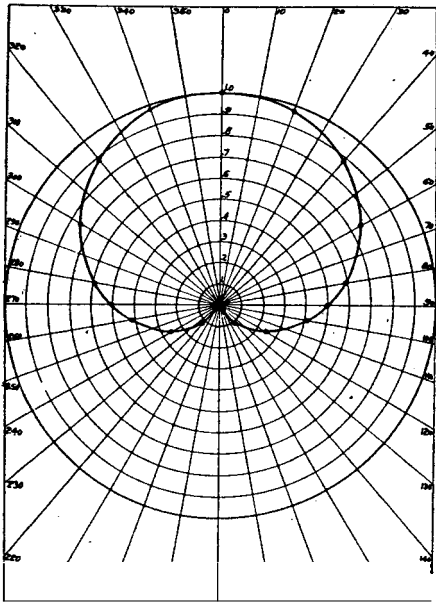

FIG. 74—DIRECTIVE CURVE OF LOOP



opposite to the desired signal. The spacing of the loops is preferably between an eighth and a quarter wave length. Compared with systems which obtain their directivity in a small space, the full length wave antenna has the advantage mentioned in connection with the discussion of short wave antennas, namely, that the signal currents developed are strong in comparison with residuals, and therefore there is a better chance of

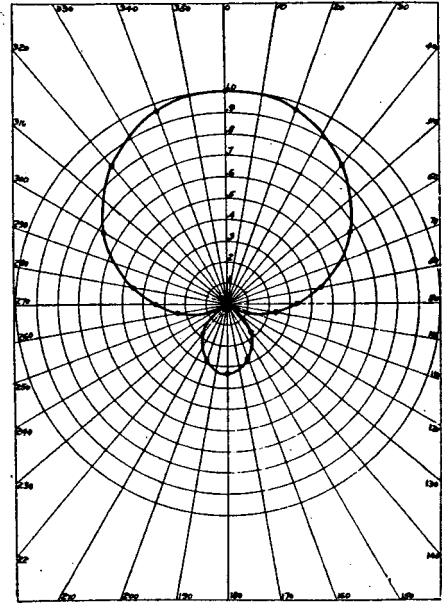

FIG. 76—DIRECTIVE CURVE FOR LOOP AND VERTICAL (VERTICAL GIVING HALF INTENSITY OF LOOP)

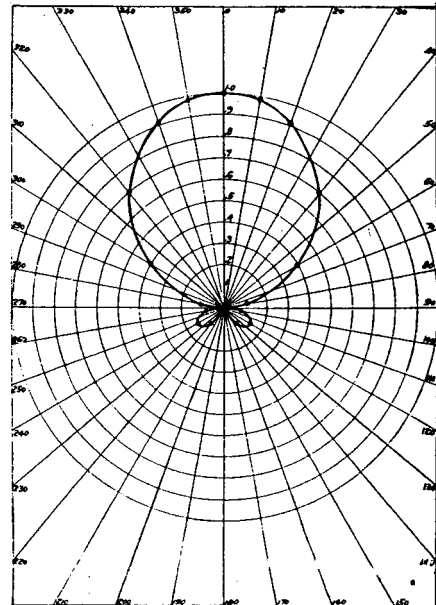

FIG. 77—DIRECTIVE CURVE FOR TWO LOOPS AN EIGHTH WAVE LENGTH APART

A number of antenna arrangements have been used which are considerably more directive than the loop and vertical. The calculated directive curves of some of these are very similar to that of the one-wavelength, full-velocity wave antenna. Fig. 77 shows the directive curve of a pair of loops spaced apart in the direction of signal propagation, the currents from the two loops being combined in the receiving circuit in such phase as to neutralize for disturbances coming from a direction

realizing in practise the directive properties predicted by calculation.

Reference to Figs. 35 to 41 and 44 shows that the areas of the directive curves of wave antennas are small, that the areas of the back and lobes of the curves are



very small so that disturbances coming from any direction more than 90 deg. from the signal have relatively **small** effect, and we have shown in the discussion of the reflection balance, that a blind spot can be produced for any direction more than 90 deg. from that of the signal. The benefit resulting from reduction in directive curve area is illustrated by the fact that in a number of ~~com-~~parisons the full wave antenna has always shown noticeably better stray ratios than an antenna half the length, although the difference in calculated area is comparatively slight.

**Directive Effects for Impulses.** The question will naturally arise whether directivity curves calculated for continuous waves, are applicable to the steep wave fronts and pulses of static. The experimental evidence is that they are applicable. It is clear that in the case of the wave antenna, waves on the wire will build up in the direction of travel of the space wave, and relatively feeble waves will reach the opposite end of the antenna, whatever the wave shape or number of waves in the train. As applied to antennas or circuits in which a balance of some ~~sort~~ is employed, to give zero reception for continuous waves from certain directions, the explanation of our experience with static is to be found in the great frequency selectivity of our receiving sets. Harmonic analysis of a pulse would show it to be equivalent to the sum of a large number of trains of waves of different frequencies. Of these the receiving set rejects all but the waves of signal frequency. Another view of the problem is the following:

Any circuit which produces a balance or zero reception for continuous waves of a certain frequency will react to a single pulse in such a way as to cause a second pulse in the opposite direction, simultaneously or a whole number of cycles later, or else a second pulse in the receiver in the same direction as the original, but an odd number of half cycles later. The receiving set has a tuned circuit and a detecting system which integrates over many cycles the effects of the oscillation of the tuned circuit. If the neutralizing pulse is simultaneous with the original, the tuned circuit is unaffected; otherwise the tuned circuit is set into oscillation by the initial pulse, but immediately stopped by the neutralizing pulse. The integrated effect of the brief oscillation is comparatively slight. If there were no neutralizing pulse the tuned circuit would (assuming a reasonably low loss circuit), execute something like a hundred oscillations before the amplitude is reduced to half the initial value.

While we have discussed static as if it consisted of single pulses or of waves of very high decrement, it may well be that some of our static consists of trains of many waves of a fairly constant frequency. The wave antenna, being aperiodic, provides a means of studying some of these disturbances without altering their character. If we insert an ordinary telephone receiver in the ground lead, at one end of a wave antenna, we hear a variety of "crackling" and "sputtering" noises,

some of which coincide with the static disturbances in the radio receiving sets. Among these noises is an occasional "ping," or sound of definitely musical character, resembling the sound given out when a bare telephone or telegraph wire is struck a sharp blow. No such sound in the receiver is heard, however, when the outside wire is actually struck.

The manner in which such continuous trains of waves might originate is not evident, but the following analogy is of interest. If you throw a stone into the water, you will note two or three circular waves as soon as the splash has subsided. Three or four seconds later you can count seven or eight waves, of substantially uniform size with a calm area inside, and after some ten seconds there may be a dozen to twenty waves. This analogy may have no significance in connection with ether waves, but it suggests a possibility. If it is true that static contains trains of waves of moderately low decrement, this would in part explain the failure of attempts to improve stray ratio by interior circuits (apart from the frequency selectivity obtainable by highly tuned circuits) and point to the conclusion that increased directivity must be our main reliance for further improvements in receiving through static.

#### GENERAL ENGINEERING FEATURES

**Type of Construction.** It is brought out in the discussion of the theory that, so far as collecting signal energy is concerned, there is no object in placing the wires of a wave antenna higher than is required for security and to pass obstructions. A high line will show slightly greater wave velocity and less attenuation than a low line, and be less affected by changes in ground conditions or proximity of trees, which sometimes cause sufficient changes in the line constants to give rise to slight reflections. The differences in favor of the higher line, however, are so small that they would rarely warrant the expense of taller poles.

Apart from the importance of a straight line and avoiding proximity of other conductors, the specifications for wave antenna construction might be taken bodily from those written for an open wire copper telephone circuit. Any change in construction or material which will appreciably alter the line impedance and give rise to reflections, should be avoided. Special care should be given to obtaining clean surfaces for making joints, since we are dealing with voltages which, on the average, are hardly a tenth of those developed in ordinary telephone circuits. Sleeve joints are recommended for permanence. The smallest copper wire which will stand the storms will make as satisfactory an antenna as a heavier wire. Good balance, where two wires are used, is important, and for this reason first-class insulation should be provided. We have seen that a single-wire antenna shows lower attenuation and higher velocity than a two wire antenna. For the same reasons, although in less degree, the use of small wire, and placing the wires near together (if

the antenna consists of several wires in multiple) is **conductive** to high velocity and **small** attenuation.

Except for temporary or experimental purposes, **two-wire** antennas are practically always desirable, since they **permit** adjustments in the station for putting out "back end" disturbances. The **use** of more wires will, in some cases, collect slightly more energy, but has **no** other advantage.

Whether a **minimum** of attenuation and a high velocity are desirable depends primarily on the length of the antenna. For an antenna a wave-length long, the best directive properties are obtained with a velocity between **0.7** and **0.8** of that of light. Higher velocities are desirable for longer antennas and lower velocities for shorter antennas; These considerations may govern the choice of number of wires, or other features of the design. It may even be desirable, in some cases, to reduce the wave velocity of the antenna below the natural value, by loading. The loading may be done by adding series inductance, with the effect of raising the line impedance and reducing the attenuation, as well as reducing the velocity. Slowing down the line by adding capacity to ground will lower the impedance and increase the attenuation. The amount of attenuation experienced on antennas consisting of bare wires on poles, does not appear to affect their directive properties adversely.

**Location of Antenna.** The land chosen for a wave antenna should be as flat and uniform as possible. The desired location of the receiving station need not control the selection of the location for the antenna. Parallels with other wire lines are to be avoided as far as possible, since the foreign lines, acting as antennas, pick up disturbance from various directions and introduce these into the antenna by induction. There is no simple way of balancing out this induction, for both the lines and the antenna are acting as ground return circuits. It is possible to prevent detrimental effects from adjacent

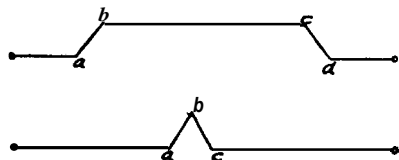

FIG. 78—EQUALLY CROOKED ANTENNAS WHICH ARE NOT EQUIVALENT

lines by loading them so as to prevent their carrying radio frequency currents. The importance of a straight right of way depends in part on the desired over-all velocity, which, in turn, depends on the length employed. Considerable deviations from a straight line affect the directive properties of the antenna, not only by reducing its wave velocity, but by altering the electromotive forces induced in it. For example, the antenna shown in Fig. 78A would receive disturbances from a direction at right angles to the mean line of the antenna, since the electromotive forces in the sections

$a-b$  and  $d-c$  would by no means neutralize. On the other hand, in Fig. 78B, the sections  $a-b$  and  $c-b$ , which are affected by disturbances at right angles to the antenna, are a small fraction of a wave length apart, and the effects of the disturbance would nearly neutralize each other in the two sections.

It is important to provide grounds at the ends of the antenna which will not change sufficiently to upset adjustments. A body of water in which several hundred feet of copper wire can be laid is the most desirable terminal for the antenna, but fairly satis-

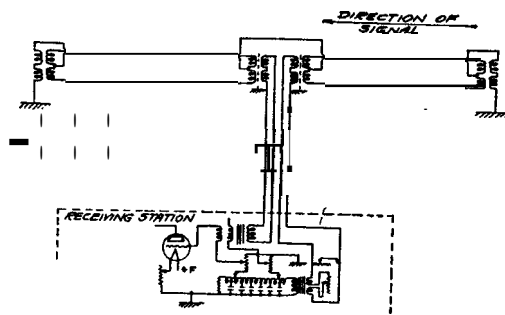

FIG. 79—ARRANGEMENT PERMITTING LOCATION OF RECEIVING STATION AT A DISTANCE FROM THE ANTENNA

factory grounds can be made by burying sufficient lengths of wire. Beverage found on Long Island that, for grounds of this type, it was best to lay the wire in the sod rather than bury it deeper, since the humous of the surface soil retains its moisture better than the sand below. A star consisting of ten or a dozen 100 foot radii of 0.081 in. copper wire laid in this way usually gives a resistance as low as 20 to 40 ohms.

**Location of Receiving Station.** In the cases of the wave antennas which have so far been built, the receiving station has been located at the end nearest the transmitting station and the signals sent back over the transmission line as illustrated in Fig. 18. Figs. 79 and 80 show arrangements by which the receiving station may be located some distance from the antenna. Effective damping must be provided at the end A, and this can be done either by wasting most of the energy in a resistance at A and transmitting to the station only so much as is necessary for compensation, or by using close coupled transformers of proper ratio to fit the impedance of the circuits which they connect together, and effectively damping the transmission lines in the station. Experience has shown that signals can easily be transmitted a number of miles over open wire lines, with comparatively little loss of intensity, and if we start with signals of such intensity<sup>25</sup> as is usually obtained from a full wave length antenna, there is no perceptible impairment of stray ratio. For the transmission lines which are not a part of the antenna, there is no object in avoiding parallels with other

25. The quietness and balance of a two-wire transmission line are not absolute, and if we attempted to transmit very weak signals, they would obviously suffer in stray ratio.

circuits, but they should be transposed frequently enough to prevent picking up radio frequency currents by induction from other circuits.

Transmission lines will inevitably act as antennas and waves will be built up on them by disturbances traveling parallel with the direction of the transmission lines. If the lines are balanced, these waves will cause no difference of potential between wires, but only potentials to ground. Balanced transformers at the ends, with electrostatic shielding between primary and secondary, will in general suffice to prevent any effects of the parasitic waves from entering the receiver. Cases may arise, however, in which the waves built up on the transmission line are especially strong, making adequate balance difficult. There are several possible measures for reducing the antenna effects of the transmission lines, such as

1. Loading to give low velocity.
2. Sectionalizing with transformers.
3. Draining.

If the loading coils in the two wires are inductively coupled, they may be made to introduce comparatively

common resistance in the ground. Fig. 82 shows a circuit designed to isolate a portion of a telephone line for antenna purposes. This provides both chokes and a drain, and the coils and condensers are proportioned to cause minimum interference with the passage of the telephonic currents. If the grounding of the wires through the 0.3 microfarad condensers makes the telephone line noisy, a 0.2 microfarad condenser in the ground lead will reduce this tendency.

All parallel wires, which are not used as part of the antenna should be sectionalized for radio frequency currents, either by coils, or by links of artificial line like that shown in Fig. 82, at intervals of a quarter or a third wave-length or less, of the shortest waves for which the antenna is to be used.

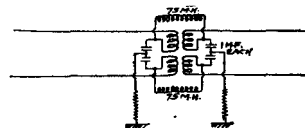

FIG. 81—SECTIONALIZING TRANSFORMER FOR TRANSMISSION LINES, WITH BY-PASS FOR DIRECT CURRENT

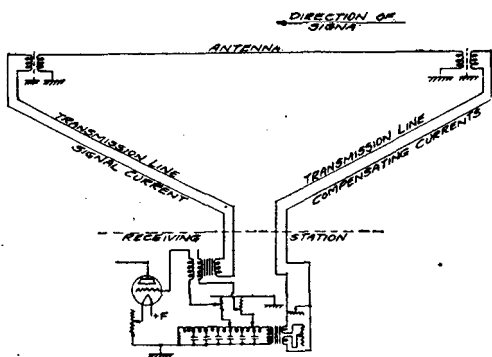

FIG. 80—ALTERNATIVE TO FIG. 79

little inductance in the transmission line and a higher inductance in the ground return line. A short-circuited secondary of suitable resistance will cause high loss to radio frequency currents in the two wires in multiple, but have no effect on the currents in the metallic circuit.

Sectionalizing as shown in Fig. 81 is one of the most effective means of preventing antenna effects in a transmission line. Drains from the neutrals of the transformer are also shown, to dissipate energy and prevent standing waves from building up.

**Use of Existing Wires for Antenna.** Existing copper wire lines, if uniform throughout the required length, and having the proper bearing, may be utilized as wave antennas. If the wires are in use for telegraph service, coils of 0.075 to 0.1 henry inductance may be used to isolate the part of the line which is to be used as an antenna. The remainder of the line may be drained through condensers if objectionable disturbances get past the coils into the antenna section. Unless the antenna ground is of very low resistance the ground for the drain should be separate, in order that disturbances will not be carried through to the antenna, owing to

The principal disadvantages of using telegraph or telephone wires for an antenna are the compromise antenna design which is likely to result, and the difficulty of making tests on the antenna for balance or leakage. The latter applies especially to telegraph lines. If the wires are used for telephony only, large stopping condensers which will permit the telephone ringing currents to pass, may be introduced in series with the wires, at the ends of the antenna, thus permitting direct current tests to be made on the antenna.

**Antenna Testing.** In any permanent receiving system it should be possible, from the station, to test the continuity and insulation of the antenna and the balance or quietness of the transmission line. Fig. 83 shows an

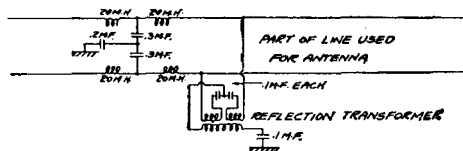

FIG. 82—ISOLATION OF PART OF TELEPHONE LINE FOR USE AS ANTENNA

arrangement which Beverage applied to the Riverhead antenna. With the switch  $S_1$  open, the line is insulated from ground and may be tested for leakage by voltmeter or megger. Throwing the switch  $S_2$  to the battery side operates the relay at the far end of the antenna. This cuts out the reflection transformer, and if the transmission line is balanced the receiving set becomes almost entirely quiet. Fig. 84 shows the application of the same method of testing to the case where the receiving station is connected through transmission lines to the antenna. Arrangements for more complete tests are obviously possible, employing polarized relays or

selector switches, but the need of any more elaborate testing system has not yet arisen.

**Protection.** Potentials of several hundred volts are not uncommon on the wave antenna, even with no storm in the immediate vicinity. All coils which may have to stand these voltages should therefore have substantial insulation. Condensers rated at 1000 volts have been used in the installations at Belmar, Chatham, and Riverhead. Vacuum tube lightning arresters rated at 360 volts are connected between antenna wires and ground at both ends. The switch  $S_1$ , in Fig. 83, is closed except during tests, to prevent static potentials from accumulating.

**Apparatus Used with Wave Antenna.** Some idea of the design of the essential pieces of apparatus which go with the wave antenna, may be of interest.

The reflection transformer for long wave work consists of three 84 turns "pancake" coils. The two outside coils in series constitute the secondary winding

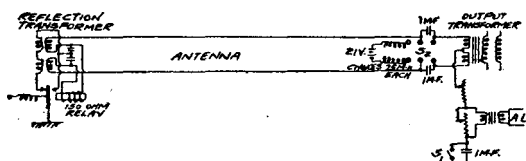

FIG. 83—ARRANGEMENTS FOR INSULATING AND BALANCE TESTS

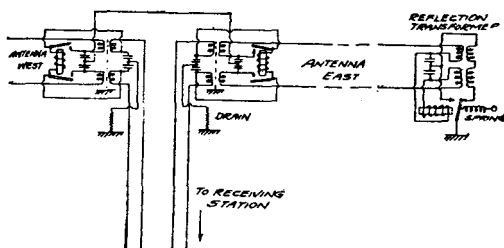

FIG. 84—RELAY CIRCUIT FOR TESTING ANTENNA OVER TRANSMISSION LINES

which is connected between the antenna wires. The middle coil, which is the primary winding, is connected from ground to the neutral of the secondary. Each coil is approximately 8 in. by 11 in. diameter by 1/2 in. thick. The conductor consists of seven strands of 0.010 in. wire with double cotton covering and a cotton braid, thus giving a loose, low-capacity winding. The whole transformer is placed in a wooden box which is filled with paraffin to exclude moisture. The following readings show the inductance:

Primary (84 turns) with secondary open . . . . .	2.4 millihenrys
Primary with secondary short-circuited . . . . .	0.56 "
Secondary (168 turns) with primary open . . . . .	7.5 "
Secondary with primary short-circuited . . . . .	1.2 "

An arrangement suggested by Kellogg eliminates the

reflection transformer. This consists in grounding one wire of the antenna and leaving the other open-circuited. The signal wave currents built up on the antenna flow in the same direction in the two wires. When the waves reach the end of the antenna, reflections occur in opposite phase on the two wires, so that the waves which travel back toward the receiving station are of opposite sign, and are received by a transformer in the station connected across from wire to wire, exactly as is the case when a reflection transformer is used.

Iron core transformers have been used for the antenna output, or between the transmission line and the receiving set. The core is of 0.0015 in. enamelled iron, and is approximately a square inch in cross-section. The primary, or line winding, is in two equal coils of 60 turns each, placed symmetrically on the core and symmetrically with respect to the secondary windings. There are four secondary windings of 160 turns each with a grounded tinfoil shield between each winding and the next to prevent electrostatic coupling. The secondary windings are connected to the grids of pliotron tubes. A greater step-up ratio might have been employed, with consequent increase in signal strength, but the method of compensation, or "back end balance," did not provide sufficient potentials to permit using any more secondary turns on the output transformer.

Another type of antenna output transformer has been used in which the secondary winding is connected directly in series with a tuned circuit of the receiving set. This transformer was essentially like the one already described, except that the secondary windings were of ten turns each.

The artificial line which is used to adjust phase for the back end compensation, consists of a wooden cylinder 4 inches (10 cm.) in diameter, on which is wound a single layer 36 in. long of 0.0126 enamelled copper wire spaced 46 turns per inch. A tap is brought out, 3/4 in. from the end, and every 1 1/2 inches thereafter, giving a total of 24 taps. A 0.005 microfarad condenser is connected from each winding tap to the common conductor, which forms the other side of the "line." A damping resistance of about 400 ohms, wound on a card, is connected across one end of the line. The line has an electrical length of about 16,000 meters and an intensity loss of about 5 per cent from end to end. Four sliders are provided, with double-contact phosphor bronze springs which bear lightly on the Wires of the solenoid.

A trap to prevent interference from the transmitting station at Marion, Mass., which is directly in front of the Riverhead antenna, was used to advantage by Beverage. This consisted in a low-resistance series tuned circuit (about 15 millihenrys and a 0.005 microfarad variable air condenser) connected between the wires of the antenna in the station, thus shunting the primary of the output transformer. This formed such a low-impedance shunt when tuned to Marion's wave length as to practically extinguish his signals. Subse-

quently, with receiving sets in which additional frequency selectivity was provided, this shunt trap was omitted, but it has a field of usefulness, and the high power factor of the circuit, where it is applied, makes its operation simple and satisfactory.

**Application to Short Waves.**<sup>26</sup> We have discussed the wave antenna as applied to long wave reception only; that is, to the reception of waves ranging from 7000 to 25,000 meters, used in transoceanic communication. It was in this field that the need of greater directivity in reception seemed most urgent, and in this field that the wave antenna was developed. The writers early demonstrated, in the short wave tests at Schenectady, that the wave antenna functioned in the same way on short waves as on long waves.

The first commercial application to shorter waves was the construction of a 2000-meter antenna at Chatham, Mass., for ship reception. This antenna was built in the summer of 1921 and is used for receiving traffic from ships having 1800 to 3000 meter continuous wave transmitting sets. It was in no wise a disappointment, for it resulted in a great improvement in reception, making it possible to receive ships from practically all the way across the Atlantic.

The next important trial of the wave antenna for short wave reception was during Mr. Paul F. Godley's transoceanic reception tests at Ardrossan, Scotland. Using a wave antenna about 400 meters long, pointed toward the United States, and using the best short wave receiving apparatus obtainable, Mr. Godley copied messages from many American amateur stations, on wave lengths between 200 and 300 meters. He attributed much of his success to his directive receiving antenna. Descriptions of the tests and of the antenna, written by Mr. Godley, were published in the February, 1922, Q. S. T., and the March, 1922, Wireless Age.

Recently the writers have done some experimenting with wave antennas for wave lengths in the 300 to 400 meter range. The advantage of the wave antenna on long waves in giving especially strong signals, is less apparent on short waves. The principal reason for this is that, for short waves, the static antennas or loops which we use as a basis of comparison are much larger in proportion to the wave antenna than is true in the case of antennas used in long wave reception.

The advantage, then, of the wave antenna for receiving waves of 450 meters or less, lies in its directive properties. Many amateurs wish to hear all the stations within range, but where the object is to receive from a certain direction only, and to exclude as much else as possible, the wave antenna will perform its function as well as on long waves.

The form of antenna best for short wave reception is practically the same as for long waves, although it will in general be desirable to reduce the height, in

order to lessen the effect of the vertical conductors at the ends. Fig. 85 shows suitable arrangements for short wave reception. The surge impedance for a given type of construction will be slightly less on short waves than on long waves. The double wire antenna with reflection transformer has a decided advantage in convenience compared with a single-wire antenna. The equivalent of the reflection transformer—namely, grounding one wire and leaving the other open-circuited; will, as a rule, be preferred for its simplicity. Rear end compensation by means of the reflection balance is desirable and easily applied. This calls for a series-tuned circuit in series with the surge impedance, as shown in Fig. 85. The resistance should be variable and the capacity reactance and inductive reactance should preferably not exceed about 500 ohms each. For output a coil of about 0.1 millihenry in the ground lead of a single-wire antenna, or, if the reflection transformer system is followed, a 0.2 millihenry coil connected between the two wires of the antenna is suitable. The first tuned circuit of the receiving set may then be coupled to this output coil.

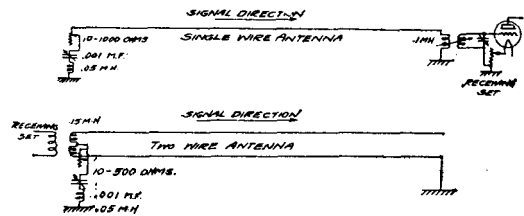

FIG. 85—ARRANGEMENTS FOR SHORT WAVE RECEPTION

APPENDIX A

Typical Operations with Vector Quantities

For additions or subtractions, vectors must be expressed in terms of their components,

$$(a + jb) + (c + jd) = (a + c) + j(b + d)$$

$$(a + jb) - (c + jd) = (a - c) + j(b - d)$$

The vector  $a + jb$  has a length  $\sqrt{a^2 + b^2}$  and an angle  $\tan^{-1} b/a$ .

Letting  $\varphi$  stand for the angle  $\tan^{-1} b/a$ ,  $a = \sqrt{a^2 + b^2} \cos \varphi$  and  $b = \sqrt{a^2 + b^2} \sin \varphi$  whence  $a + jb = \sqrt{a^2 + b^2} (\cos \varphi + j \sin \varphi)$ .

There are several other ways of expressing a vector in terms of its length and angle  $a + jb = (\sqrt{a^2 + b^2}) e^{j\varphi}$  if  $\varphi$  is expressed in radians or  $a + jb = (\sqrt{a^2 + b^2}) e^{j(\varphi^\circ/57.3)}$  if  $\varphi^\circ$  is expressed in degrees.  $a + jb = \sqrt{a^2 + b^2} / \varphi$  if we define the symbol  $/\varphi$  as meaning that the quantity  $\sqrt{a^2 + b^2}$  after which it appears is to be multiplied by  $\cos \varphi + j \sin \varphi$ .

The identity of  $e^{j\varphi}$  and  $\cos \varphi + j \sin \varphi$  is most readily shown by expanding  $e^{j\varphi}$ ,  $\cos \varphi$ , and  $\sin \varphi$  in power series, and replacing  $j^2$  by  $-1$ . This relation is shown in a number of text books.

The product of two vectors is found by multiplying their lengths together and adding their angles.

26. For more detailed discussion of the application to short wave reception, see article by H. H. Beverage in Q. S. T., Nov. 1922.

Thus  $(A / \varphi_1) (B / \varphi_2) = A \times B / \varphi_1 + \varphi_2$

$$(a + j b) (c + j d) = (\sqrt{a^2 + b^2}) (\sqrt{c^2 + d^2}) / \tan^{-1} b/a + \tan^{-1} d/c$$

To divide one vector quantity by another we take the quotient of their lengths and the difference of their

angles,  $\frac{A / \varphi_1}{B / \varphi_2} = A/B / \varphi_1 - \varphi_2.$

Multiplication and division may also be performed with the vectors in the form  $a + j b$ , thus  $(a + j b) (c + j d) = a c + j a d + j b c + j^2 b d = (a c - b d) + j (a d + b c)$

$$\frac{a + j b}{c + j d} = \frac{(a + j b)}{(c + j d)} \times \frac{(c - j d)}{(c - j d)} = \frac{(ac + bd) + j(-ad + bc)}{c^2 + d^2}$$

In the foregoing any component or any angle may have a negative sign.

In the expression  $a + j b = \sqrt{a^2 + b^2} (\cos \varphi + j \sin \varphi)$  where  $\varphi = \tan^{-1} b/a$  the quantity  $\sqrt{a^2 + b^2}$  taken by itself would have zero phase angle, and the quantity  $(\cos \varphi + j \sin \varphi)$  has a phase angle  $\varphi$  and a length unity (since  $\cos^2 \varphi + \sin^2 \varphi = 1$  and therefore  $\sqrt{\cos^2 \varphi + \sin^2 \varphi} = 1$ ). Multiplying by  $\cos \varphi + j \sin \varphi$ , or its equivalent  $\epsilon^{j\varphi}$  thus simply causes a counter-clockwise rotation or phase advance by the amount of the angle  $\varphi$ . Multiplying by  $\epsilon^{-j\varphi}$  or  $\cos(-\varphi) + j \sin(-\varphi)$  which is  $\cos \varphi - j \sin \varphi$ , causes clockwise rotation or phase retardation by the amount of the angle  $\varphi$ .

From the rule for multiplication it follows that to square a vector quantity we square its length and double its angle. Thus  $(A / \varphi)^2 = A^2 / 2\varphi$  and conversely to find the square root of a vector we take the square root of its length and divide its angle by two,  $\sqrt{A / \varphi} = \sqrt{A} / 1/2\varphi$ .

Differentiation of a vector quantity A, with respect to some variable X, on which A depends, gives the vector change in A per unit change in X.

$$\frac{d A}{d x} = \frac{A_2 - A_1}{x_2 - x_1}$$

in which  $A_2 - A_1$  is a vector difference,  $A_1$  is the value of A corresponding to  $X_1$  and  $A_2$  that corresponding to  $X_2$ , and  $X_2$  differs from  $X_1$  by an infinitesimal amount.

In Fig. 62A a vector connecting the ends 1 and 2 of the total current vectors, corresponding to  $x = 1$

and  $x = 2$ , would represent  $\frac{d I}{d x}$  corresponding to a value 1.5 for X.

Integration of a vector quantity gives the vector sum of an infinite number of infinitesimal vectors. This process is illustrated, using finite numbers, in Figs. 28 and 33.

APPENDIX B

Analysis of Action of Wave Antenna

The following treatment of the problem of the wave antenna, was worked out by Mr. Ivar Herlitz or Kellogg's request. Mr. Herlitz was at the time pursuing graduate studies in electrical engineering at Union College as exchange student of the American Scandinavian Foundation. The treatment is given here partly by way of acknowledgment for the substantial assistance derived from Mr. Herlitz's solution of the problem, at an early date in the evolution of the theory of the antenna, and partly because the equations are derived in a radically different manner, and provide a valuable means of checking results as calculated by the expressions given in the body of the paper.

Referring to Fig. 26,  $x$  is a distance measured along the antenna from the end A, nearest the source of signals, and  $l$  is the total length of the antenna.

As in the discussion given in the paper, the induced voltage per unit length of wire at the point X, is taken as

$$E_x = E_0 \cos \theta \epsilon^{-j \omega x (\cos \theta) / v}$$

The following new symbols will be used.

$i$  = current in wire at X

$e$  = potential of wire at X, with respect to ground.

The potential gradient along wire is the resultant of that due to the passage of current through the line inductance and resistance, and the voltage induced in the wire by the space wave, or

$$\frac{d e}{d x} = - (R + j \omega L) i + E_0 \cos \theta \epsilon^{-j \omega x (\cos \theta) / v} \tag{52}$$

The current in the wire changes from point to point by the amount of the leakage and charging currents, or

$$\frac{d i}{d x} = - (G + j \omega C) e \tag{53}$$

Differentiating (53) and solving for  $\frac{d e}{d x}$  gives

$$\begin{aligned} \frac{d_2 i}{d x^2} &= - (G + j \omega C) \frac{d e}{d x} \\ \frac{d e}{d x} &= - \frac{1}{(G + j \omega C)} \frac{d_2 i}{d x^2} \end{aligned} \tag{54}$$

Substituting this in (52) and multiplying through by  $-(G + j \omega C)$  gives

$$\begin{aligned} \frac{d_2 i}{d x^2} &= (R + j \omega L) (G + j \omega C) i \\ &\quad - (G + j \omega C) E_0 \cos \theta \epsilon^{-j \omega x (\cos \theta) / v} \end{aligned} \tag{55}$$

or since  $(R + j \omega L) (G + j \omega C) = \gamma^2$

$$\frac{d_2 i}{d x^2} = \gamma^2 i - (G + j \omega C) E_0 \cos \theta \epsilon^{-j \omega x (\cos \theta) / v} \tag{56}$$

Use trial solution of the form

$$i = A \epsilon^{\gamma x} + B \epsilon^{-\gamma x} + D \epsilon^{-j \omega x (\cos \theta) / v} \tag{57}$$

Differentiating (57)

$$\frac{d i}{d x} = \gamma A \epsilon^{\gamma x} - \gamma B \epsilon^{-\gamma x} - j \frac{\omega \cos \theta}{v} D \epsilon^{-j \omega x (\cos \theta) / v} \quad (58)$$

$$\frac{d^2 i}{d x^2} = \gamma^2 A \epsilon^{\gamma x} + \gamma^2 B \epsilon^{-\gamma x} - \frac{\omega^2 \cos^2 \theta}{v^2} D \epsilon^{-j \omega x (\cos \theta) / v} \quad (59)$$

We next substitute the value of  $i$  given in (57) and the value of  $\frac{d^2 i}{d x^2}$  given in (59) in equation (56)

$$\gamma^2 A \epsilon^{\gamma x} + \gamma^2 B \epsilon^{-\gamma x} - \frac{\omega^2 \cos^2 \theta}{v^2} D \epsilon^{-j \omega x (\cos \theta) / v} = \gamma^2 A \epsilon^{\gamma x} + \gamma^2 B \epsilon^{-\gamma x} + \gamma^2 D \epsilon^{-j \omega x (\cos \theta) / v} - (G + j \omega C) E_0 \cos \theta \epsilon^{-j \omega x (\cos \theta) / v}$$

from which

$$D \left( \gamma^2 + \frac{\omega^2 \cos^2 \theta}{v^2} \right) = (G + j \omega C) E_0 \cos \theta$$

$$D = \frac{(G + j \omega C) E_0 \cos \theta}{\gamma^2 + \frac{\omega^2 \cos^2 \theta}{v^2}} \quad (60)$$

Using this value of  $D$  in (57), we have as the general expression for current

$$i = A \epsilon^{\gamma x} + B \epsilon^{-\gamma x} + \frac{(G + j \omega C) E_0 \cos \theta}{\gamma^2 + \frac{\omega^2 \cos^2 \theta}{v^2}} \epsilon^{-j \omega x (\cos \theta) / v} \quad (61)$$

The constants  $A$  and  $B$  depend on the terminal impedance and we must find an expression for the voltage  $e$ , as well as the current  $i$ , in order to evaluate them.

From (53)

$$e = - \frac{1}{(G + j \omega C)} \frac{d i}{d x}$$

in which we may substitute the value of  $\frac{d i}{d x}$  given in (58) using the value given in (60) for  $D$

$$e = \frac{-\gamma A \epsilon^{\gamma x}}{G + j \omega C} + \frac{\gamma B \epsilon^{-\gamma x}}{G + j \omega C} + \frac{j \frac{\omega \cos \theta}{v} E_0 \cos \theta}{\gamma^2 + \frac{\omega^2 \cos^2 \theta}{v^2}} \epsilon^{-j \omega x (\cos \theta) / v}$$

Since  $\frac{\gamma}{G + j \omega C} = Z$ , the expression for  $e$  becomes.

$$e = -Z A \epsilon^{\gamma x} + Z B \epsilon^{-\gamma x} + \frac{j \frac{\omega \cos \theta}{v} E_0 \cos \theta}{\gamma^2 + \frac{\omega^2 \cos^2 \theta}{v^2}} \epsilon^{-j \omega x (\cos \theta) / v} \quad (62)$$

For an antenna with non-reflecting ends, or in other words, with the surge impedance at each end,

$$e = -Z i \text{ for } x = 0$$

$$e = +Z i \text{ for } x = l$$

Using the expressions for  $i$  and  $e$  given in (61) and (62) we set  $x = 0$  and equate  $-Z i$  to  $e$ , and have

$$-Z A - Z B - Z \frac{(G + j \omega C) E_0 \cos \theta}{\gamma^2 + \frac{\omega^2 \cos^2 \theta}{v^2}} = -Z A + Z B + \frac{j \frac{\omega \cos \theta}{v} E_0 \cos \theta}{\gamma^2 + \frac{\omega^2 \cos^2 \theta}{v^2}}$$

whence

$$-2 Z B = \frac{E_0 \cos \theta}{\gamma^2 + \frac{\omega^2 \cos^2 \theta}{v^2}} \left\{ j \frac{\omega \cos \theta}{v} + Z (G + j \omega C) \right\}$$

and since  $Z (G + j \omega C) = \gamma$

$$B = - \frac{E_0 \cos \theta}{2 Z} \frac{\gamma + j \frac{\omega \cos \theta}{v}}{\gamma^2 + \frac{\omega^2 \cos^2 \theta}{v^2}} = - \frac{E_0 \cos \theta}{2 Z \left[ \gamma - j \frac{\omega \cos \theta}{v} \right]} \quad (63)$$

Next setting  $x = l$  in (61) and (62) and equating  $+Z i$  to  $e$  we have

$$Z A \epsilon^{\gamma l} + Z B \epsilon^{-\gamma l} + Z \frac{(G + j \omega C) E_0 \cos \theta}{\gamma^2 + \frac{\omega^2 \cos^2 \theta}{v^2}} \epsilon^{-j \omega l (\cos \theta) / v} = -Z A \epsilon^{\gamma l} + Z B \epsilon^{-\gamma l} + \frac{j \frac{\omega \cos \theta}{v} E_0 \cos \theta}{\gamma^2 + \frac{\omega^2 \cos^2 \theta}{v^2}} \epsilon^{-j \omega l (\cos \theta) / v}$$

$$2 Z A \epsilon^{\gamma l} = \frac{E_0 \cos \theta \epsilon^{-j \omega l (\cos \theta) / v}}{\gamma^2 + \frac{\omega^2 \cos^2 \theta}{v^2}} \left[ j \frac{\omega \cos \theta}{v} - Z (G + j \omega C) \right]$$

$$= - \frac{E_0 \cos \theta \epsilon^{-j \omega l (\cos \theta) / v}}{\gamma^2 + \frac{\omega^2 \cos^2 \theta}{v^2}} \left[ \gamma - j \frac{\omega \cos \theta}{v} \right]$$

$$= - \frac{E_0 \cos \theta \epsilon^{-j \omega l (\cos \theta) / v}}{\gamma + j \frac{\omega \cos \theta}{v}}$$

$$A = \frac{-E_0 \cos \theta \epsilon^{-j \omega l (\cos \theta) / v}}{2 Z \epsilon^{\gamma l} \left( \gamma + j \frac{\omega \cos \theta}{v} \right)} = - \frac{E_0 \cos \theta \epsilon^{-(\gamma + j \omega l (\cos \theta) / v)}}{2 Z \left( \gamma + j \frac{\omega \cos \theta}{v} \right)} \quad (64)$$

With these values for **A** and **B** and with  $\gamma/Z$  substituted for  $G + j\omega C$ , equation (61) for current becomes

$$\mathbf{i} = \mathbf{E}_0 \cos \theta \left\{ \frac{-\epsilon^{-(\gamma + j\omega l (\cos \theta)/v)}}{2Z \left( \gamma + j \frac{\omega \cos \theta}{v} \right)} \epsilon^{\gamma x} - \frac{1}{2Z \left( \gamma - j \frac{\omega \cos \theta}{v} \right)} \epsilon^{-\gamma x} + \frac{\gamma \epsilon^{-j\omega l (\cos \theta)/v}}{Z \left( \gamma^2 + \frac{\omega^2 \cos^2 \theta}{v^2} \right)} \right\} \quad (65)$$

The receiver end current is found by letting  $x = l$  in (65) which gives

$$\begin{aligned} \mathbf{i}_b &= \mathbf{E}_0 \cos \theta \left\{ \frac{-\epsilon^{-(\gamma + j\omega l (\cos \theta)/v)}}{2Z \left( \gamma + j \frac{\omega \cos \theta}{v} \right)} \epsilon^{\gamma l} - \frac{\epsilon^{-\gamma l}}{2Z \left( \gamma - j \frac{\omega \cos \theta}{v} \right)} + \frac{\gamma \epsilon^{-j\omega l (\cos \theta)/v}}{Z \left( \gamma^2 + \frac{\omega^2 \cos^2 \theta}{v^2} \right)} \right\} \\ &= \frac{\mathbf{E}_0 \cos \theta}{2Z} \left\{ \frac{-\epsilon^{-j\omega l (\cos \theta)/v}}{\gamma + j \frac{\omega \cos \theta}{v}} - \frac{\epsilon^{-\gamma l}}{\gamma - j \frac{\omega \cos \theta}{v}} + \frac{2\gamma \epsilon^{-j\omega l (\cos \theta)/v}}{\left( \gamma + j \frac{\omega \cos \theta}{v} \right) \left( \gamma - j \frac{\omega \cos \theta}{v} \right)} \right\} \\ &= \frac{\mathbf{E}_0 \cos \theta}{2Z} \frac{\epsilon^{-j\omega l (\cos \theta)/v}}{\left( \gamma - j \frac{\omega \cos \theta}{v} \right)} \times \left\{ \frac{\left( \gamma - j \frac{\omega \cos \theta}{v} \right)}{\gamma + j \frac{\omega \cos \theta}{v}} - \epsilon^{-\gamma l} \epsilon^{+j\omega l (\cos \theta)/v} + \frac{2\gamma}{\gamma + j \frac{\omega \cos \theta}{v}} \right\} \\ &= \frac{\mathbf{E}_0 \cos \theta \epsilon^{-j\omega l (\cos \theta)/v}}{2Z \left( \gamma - j \frac{\omega \cos \theta}{v} \right)} \times \left\{ \frac{\gamma + j \frac{\omega \cos \theta}{v}}{\gamma + j \frac{\omega \cos \theta}{v}} - \epsilon^{-(\gamma - j\omega l (\cos \theta)/v)} \right\} \\ &= \frac{\mathbf{E}_0 \cos \theta \epsilon^{-j\omega l (\cos \theta)/v}}{2Z \left( \gamma - j \frac{\omega \cos \theta}{v} \right)} \left\{ 1 - \epsilon^{-(\gamma - j\omega l (\cos \theta)/v)} \right\} \end{aligned}$$

$$= \frac{\mathbf{E}_0 \cos \theta \epsilon^{-j\omega l (\cos \theta)/v}}{2Z \left[ \alpha + j\beta (1 - n \cos \theta) \right]} \times \left\{ 1 - \epsilon^{-[\alpha + j\beta (1 + n \cos \theta)] l} \right\} \quad (66)$$

The back end current is found by setting  $x = 0$  in (65) which gives

$$\begin{aligned} \mathbf{i}_a &= \mathbf{E}_0 \cos \theta \left\{ \frac{-\epsilon^{-(\gamma + j\omega l (\cos \theta)/v)}}{2Z \left( \gamma + j \frac{\omega \cos \theta}{v} \right)} - \frac{1}{2Z \left( \gamma - j \frac{\omega \cos \theta}{v} \right)} + \frac{\gamma}{Z \left( \gamma + j \frac{\omega \cos \theta}{v} \right) \left( \gamma - j \frac{\omega \cos \theta}{v} \right)} \right\} \\ &= \frac{\mathbf{E}_0 \cos \theta}{2Z \left( \gamma + j \frac{\omega \cos \theta}{v} \right)} \left\{ -\epsilon^{-[\gamma + j\omega l (\cos \theta)/v] l} - \frac{\gamma + j \frac{\omega \cos \theta}{v}}{\gamma - j \frac{\omega \cos \theta}{v}} + \frac{2\gamma}{\gamma - j \frac{\omega \cos \theta}{v}} \right\} \\ &= \frac{\mathbf{E}_0 \cos \theta}{2Z \left( \gamma + j \frac{\omega \cos \theta}{v} \right)} \left\{ 1 - \epsilon^{-[\gamma + j\omega l (\cos \theta)/v] l} \right\} \\ &= \frac{\mathbf{E}_0 \cos \theta}{2Z \left[ \alpha + j\beta (1 + n \cos \theta) \right]} \times \left\{ 1 - \epsilon^{-[\alpha + j\beta (1 + n \cos \theta)] l} \right\} \quad (67) \end{aligned}$$

### APPENDIX C

#### List of Symbols

Symbols in heavy faced type, as **I**, **E**, **Z** stand for vector quantities.

**L** = Series inductance of antenna conductors, henrys per kilometer.

**C** = Shunt capacity of antenna, farads per kilometer

**R** = Effective series resistance of antenna, ohms per kilometer

**G** = Leakage conductance to ground, mhos for one kilometer, (effective value at high frequency)

**Z** = Characteristic or surge impedance of antenna

$Z = \sqrt{\frac{R + j\omega L}{G + j\omega C}}$  or for most purposes at radio frequency  $Z = \sqrt{L/C}$

**y** = Propagation constant for antenna

$\gamma = \sqrt{(R + j\omega L)(G + j\omega C)}$

**a** = Attenuation constant per kilometer = real part of **y**. If  $\omega L$  is large compared with **R**, and  $\omega C$  large compared with **G**,  $\alpha = R/2 \sqrt{C/L} + G/2 \sqrt{L/C}$  approximately

$j\beta$  = Imaginary component of  $\gamma$ , or  $\beta$  = Wave length constant of Antenna.  $y = a + j\beta$ . For most purposes at radio frequency  $\beta = \omega \sqrt{LC}$  approximately



- $u$  = Antenna wave velocity, kilometers per second  
 $u = \omega/\beta$  or  $u = 1/\sqrt{LC}$  approximately
- $v$  = Velocity of space waves  
 = Velocity of light =  $3 \times 10^5$  kilometers per second
- $n$  = Velocity ratio of antenna =  $u/v$
- $f$  = frequency of signal waves, cycles per second
- $\lambda$  = Signal wave length =  $\frac{3 \times 10^5}{f}$  kilometers
- $w = 2\pi f$
- $\epsilon$  = Base of natural logarithms =  $2.718 \epsilon^x = 10^{0.4343x}$
- $l$  = Length of antenna in kilometers
- $\theta$  = Angle between direction of signal and direction of antenna
- $E_0$  = Measure of signal intensity = Induced volts per kilometer in horizontal conductor parallel to signal direction
- $I_b$  = Current at receiver end of antenna (both ends of antenna assumed to be damped by surge impedance).
- $I_a$  = Current at back end of antenna (both ends assumed damped)
- $\rho$  = Specific resistance of earth, ohms for one centimeter cube.

## Bibliography on Antennas

### DIRECTIONAL, GROUND, UNDERGROUND AND UNDERWATER

- E. Rotheman. Telegraphie ohne metallische Leitung. *E. T. Z.* Vol. 15. Page 616-618. 1894.
- K. Strecker. Ueber die Ausbreitung starker elektrischer Ströme in der Erdoberfläche. *E. T. Z.* Vol. 17. Page 106-110, 1896.
- F. Braun. Drahtlose Telegraphie durch Wasser und Luft. (Book). Leipzig. 1901.
- E. Lecher. Über drahtlose Telegraphie. *Phys. Zeits.* 3. 273, 274. 1902.
- F. Braun. Notizen über drahtlose Telegraphie. *Phys. Zeits.* 4. 361-364. 1903.
- E. Lecher. Über künstliche Elektrisierung der Erdkugel. *Phys. Zeitschrift*, 4. 320-321. 1903.
- L. Zehnder. German Patent No. 17886. 1904.
- L. Zehnder. English Patent No. 10601 of 1905. German Patent 178861 of 1906.
- F. Braun. Directed Wireless Telegraphy. *Electrician*, 57. 222, 244. 1906.
- R. A. Fessenden. \*Stream of Water as Antenna. *Elektrotechnische Zeitschrift*. 1906. P. 690.
- J. A. Fleming. The Theory of Directive Antenna or Unsymmetrical Hertzian Oscillators. *Proc. Royal Soc. A*, 78. 1-8; 1906. *Sci. Abs. A*. No. 2072. 1906.
- G. Marconi. Directive Antenna. *Proc. Roy. Soc. London*, 77A. 413. 1906.
- E. Bellini and A. Tosi. A Directive System of Wireless Telegraphy. *Electrical Engineering* (London) 8. 771-775 (1907) 1. 348-351 (1908); *Sci. Abs. B*. Nos. 83 and 466 (1908). *Jahrb. d. drahtl. Tel.* 1. 598-608; 1907.
- F. Braun. Gerichtete drahtlose Telegraphie. *Jahrb. drahtl. Tel.* 1. Page 1. 1907.
- G. Eichhorn. System einer gerichteten drahtlosen telegraphie noch, E. Bellini and A. Tosi. *Jahrbuch* 1, 598-608. 908. *Electrical Engineering* 2, 771-1907.

Pickard, G. W. *Elec. Rev.* 50, 963, 985; 52, 262; 53, 494; *Electrician* 59, 563, 1907.

Bellini-Tosi. Telegraphie et Telephonie sans fil dirigeables. Tosi. *Bull. Soc. Znt. des Electriciens* 8, 707-730, second series. 1908.

E. Bellini. Über einige Luftgebilde für gerichtete drahtlose Telegraphie. *Jahrbuch* 2, 381-396, 1908.

Bellini and Tosi. Methods of Obtaining Directed Waves. *Electrician* 60, 748, 1908; 61, 598, 1908; 62, 381, 1909; 62, 608, 1909.

Bellini and Tosi. Directive Wireless Telegraphy. *Proc. Phys. Soc. London*, 21, 305, 1908; *Elec. Engineering* 3, 348, 1908; Bellini, *Jahrbuch* 2, 381, 808, 1909-1910.

Blondel, A. Über die Bestimmung der Richtung von Schiffen Vermittels der Hertzchen Wellen. *Jahrbuch* 8, 190, 1908.

F. Kiebitz. Gerichtete drahtlose Telegraphie. *Verh. d. deutsch. Physik*, 10. 934-944, 1908. *Mitt. Tel. Ver.* 6, 22, 1910.

J. Zenneck. Über die Wirkungsweise der sender für gerichtete drahtlose Telegraphie. *Phys. Zeits.* 9, 553-556, 1908.

E. Bellini et A. Tosi. La Portee et les Avantages des Aeriens Dirigeables et le Radio-goniometre Bellini-Tosi. *Lumiere Elec.* 2nd series, 5, page 263-268. Feb. 27, 1909.

G. Eichhorn. Das Radio Goniometer von Bellini und Tosi. *Jahrbuch d. drahtl. Tel.* 2, 511-525. 1909.

T. Karrass. Geschichte der Telegraphie. (Book). Page 43. Brunswick, Germany, 1909, Vieweg. In Bureau of Standards library.

C. Montu. Recent Progress in Directive Wireless Telegraphy. *Elettricità* (Milan), 33, 291-293, Nov. 25, 1909. Describes Bellini-Tosi system.

Greenleaf W. Pickard. Antennae. *Proceedings of the Wireless Institute of America*. Vol. 1, No. 2, May 1909. (Meeting in New York City, May 5, 1909.)

A. Sommerfeld. Über die Ausbreitung der Wellen in der drahtlosen Telegraphie. *Ann. d. Phys.* page 665-736, 1909. *Jahrb. d. drahtl. Tel.* 4, 157-176. 1911.

H. Behnken. Eine Method zur Messung der Wirksamen Kapazität von Antennen. *Phys. Zeit.* 14, page 430-433, 1913. *Mitt. Tel. Ver.*, 7, 173, 1910.

E. Bellini. Constancy of the Coupling in the Bellini-Tosi Radiogoniometer. *Jahrbuch* 3, 571-580, 1910; *Sci. Abs. B.*, p. 420, 1911.

W. H. Eccles and A. Arton. Directive Wireless Telegraphy. *Electrician* 64, 834, 899, 947, 1910.

C. Fischer. Strahlung von Antennen. *Phys. Zeit.* 18, page 295-303, 1911. *Mitt. Tel. Ver.* 6, 103, 1910.

F. Kiebitz. Versuche über drahtlose Telegraphie mit verschiedenen Antennen formen. *Ann. d. physik.* 337, pages 941-998. 1910.

F. Kiebitz. Neuere Versuche über gerichtete drahtlose Telegraphie mit Erdantennen. *Verh. d. Deutsch. Physik Ges.* 13, 876-889. *Mitt. Tel. Ver.* 6, 158, 1910.

L. H. Walter. Radiation from Directive Aerials. *Electrician*, 64, 790, 875, 899, 945, 1910; *Sci. Abs. B*, p. 160, 1910.

L. H. Walter. Directive Wireless Telegraph Station at Boulogne. *Elec. Eng.* 6, 547-549, July 14, 1910; *Sci. Abs. B*, p. 390, 1910. See also *Sci. Abs. B*, No. 465, 1910.

Bellini and Tosi. Le Compas Azimutal Hertzien. *La Lumiere Elec.* 14, 227, 1911.

A. Blondel. Directed Aerials in Wireless Telegraphy. *Lumiere Elec.* 16, 7, 131, 1911; *Comptes Rendus* 153, 593, 661, 1911; *Sci. Abs. B*, p. 149, 1912.

A. Blondel. Notes sur les aeriens d'orientation en radio-télégraphie. *Lumiere Elec.* 26, 131. Oct. 7, 1911.

Elec. World. Antenna Investigations by Cornell Students. *Elec. World*, 58, 948, Oct. 14, 1911.

G. Leimbach. Drahtlose Telegraphie im Erdinnern. *E. T. Z.* 38, 237-238. 1911.

G. E. Petit. Method of Determining the Bearing of a Radio-

- telegraphic Station. *Lum. Elec.* 13, 227-230, 1911; *Sci. Abs. B*, p. 173, 1911.
- L. H. Walter. Accuracy of the Bellini-Tosi Wireless "Compass" for Navigational Purposes. *El.* 67, 749-751, August 18, 1911.
- F. Addey. Directional Wireless Telegraphy. *Electrician* 70, 568-588, Dec. 27, 1912. Abstract of paper read before the Institute P. O. Elec. Engr. *Electrotechnische Zeitsch* 34, 534-535, May 8, 1913. *Rev. Electrique* 19, 392-395, April 18, 1913.
- F. Braun. Earth Antennas. *Jahrbuch* 5, 586, 1912.
- W. Burstyn, Die Wirkungsweise der Erdantennen. *E. T. Z.* 33, 613, 1912. *Jahrbuch d. Tel.* 6, 10, 1912.
- W. Burstyn. The Action of Earth Antennae. *Jahrbuch* 6, 10-13, 1912. *Sci. Abs. B*, p. 518, 1912. *E. T. Z.* 33, 615, June 13, 1912.
- W. Burstyn. Die Wirkungsweise der Erdantennen. *Jahrbuch* 6, 1013, July 1912. *Elektrotechnische Zeitsch*, 33, 615-616, July 13, 1912. *Sci. Abs. B*, 1912, page 518.
- J. A. Fleming. Earthed Directive Antennae. *El.* 68, 1020, March 29, 1912.
- F. Kiebitz. Über die Geschichte der Erdantennen. *Jahrbuch* 6, 360, March 1912; 6, 1 and 554, 1912.
- F. Kiebitz. Neuere Versuche über gerichtete drahtlose Telegraphie mit Erdantennen. *Jahrb. d. drahtl. Tel.* 6, 349-360, March 1912. *Sci. Abs. B*, No. 321, 1912.
- F. Kiebitz. Versuche über gerichtete drahtlose Telegraphie. *Jahrbuch d. drahtlosen Tel.* 6, 1-9, July 1912. *Sci. Abs. B*, 1912, page 519. *Mitt. Tel. Ver.* 7, 71.
- F. Kiebitz. Recent Experiments on Directive Wireless Telegraphy with Earth Antennae. *Electrician* 68, 868, 1912.
- Mosler, Burstyn and Hausrath. Earth Antennas and Underwater Antennas. *Jahrbuch* 6, 359-366, 570-573, 1912.
- M. Reich. Relation between the Radiation of an Antenna and its Shape. *Phys. Zeits*, 13, 228, March 15, 1912. *Sci. Abs. B*, p. 300, 1912.
- A. Rothé. Reception of Radiotelegraphic Signals with Diminutive Aerials. *Comptes Rendus* Vol. 154, Jan. 27, 1912. *Sci. Abs. B*, p. 203, 1912. See also *Sci. Abs. B*, No. 321, 1912.
- E. Rothé. Reception by Earth Antennae. *Comptes Rendus*, 166, 1075, Nov. 25, 1912. *Sci. Abs. B*, p. 144, 1913.
- J. E. Taylor. Earthed Directive Antennae. *Electrician*, 68, 978, March 22, 1912.
- A. Turpani. Antennae of the Horizontal and Vertical Type. *Rev. Electrique*, 18, pp. 207-208. Sept. 13, 1912. *Sci. Abs. B*, p. 517, 1912.
- L. Zehnder. Directive Antennae. *Jahrbuch* 6, 594, June 1912. Earth Antennas. *Elektrotechnische Zeitschrift*, 33, 139, 1912. Earth Antennas. (Discussion of Kiebitz' paper). *Electrician* 68, 936, 978, 1020, 1912.
- The Telefunken "Compass". *Electrician* 69, 269, 1911; *Sci. Abs. B*, p. 304, 1912.
- F. Kiebitz. Further Experiments on Earth Antennae. (*Jahrbuch d. drahtlosen Telegraphie* 6, 554-569, March 1913. *Electrician* 71, 608-611, July 18, 1913). *Sci. Abs. B*, No. 1013, 1913.
- H. Mosler. Über die Wirkungsweise der Erdantennen. *Jahrb. d. drahtl. Tel.* 6, 570, 1913.
- Marconi Patent for Closed Aerials. British Patent 4514 of 1913. *Engineer* 116, 641, Dec. 12, 1913. *Sci. Abs. B*, p. 52, 1914.
- The Wireless Direction Finder. (Marconi) *Yearbook of Wireless Telegraphy*. pp. 306-317, 1913. Historical and descriptive.
- Direction Finding by Wireless Telegraphy. *Elek. u. Masch.* 31, 1029-1030, Nov. 30, 1913.
- E. Bellini. The Possibility of Sharp Directive Wireless Telegraphy. *Electrician* 74, 352, 1914; *Lum. Elec.* 28, 203, 1915; *Electrotechnica* 2, 89-90, Feb. 5, 1915; *Sci. Abs. B*, p. 207, 1915.
- H. Brand. Latest Developments in Wireless Telegraphy. *Verein z. Beförd. des Gewerbflusses Verh.* No. 4, pp. 225-295, April 1914. *Sci. Abs. B*, p. 449, 1914.
- F. Braun. Use of Closed Circuits in Wireless Telegraphy in Place of Open. *Jahrbuch* 8, 1-34, Jan. 1914.
- A. Artom. Directivity of Electric Waves. (*Acad. Lincei. Atti.* 94, 42-47, Jan. 21, 1915). *Electrotecnica* 9, 202-204, March 25, 1915.
- E. Bellini. La Portée des Aériens à ondes Dirigées. *La Lum. Elec.* 30, 1, 1915.
- E. Bellini. Some Details of the Direction Finder. *Electrician* 75, 776-778, 1915; *Sci. Abs. B*, p. 493, 1915.
- E. Bellini. Range of Directive Aerials. *Lum. Elec.* 30, 1-6, 1915; *Sci. Abs. B*, p. 382, 1915.
- H. Brand. Experiments in Sending with Low Horizontal Antennae. *Jahrb. d. drahtl. Tel.* 9, 431-438, 1915. *Sci. Abs. B*, p. 491, 1915.
- C. A. Culver and J. A. Riner. Radio Telegraphy without Elevated Antennae. *El. World*, 66, 723-726, March 20, 1915.
- Arthur R. Hinks. Wireless Telegraphy in Survey. *Yearbook Wireless Telegraphy*. Pages 628-636. 1915.
- R. B. Woolverton. Effectiveness of Ground Antenna on Long Distance Reception. *Proc. I. R. E.* 3, 371, December 1915.
- J. Zenneck. An Arrangement for Directive Wireless Telegraphs. *Jahrbuch* 9, 417-424, April 1915. *Sci. Abs. B*, 1915, page 450.
- J. Zenneck. Wireless Telegraphy. (Book). 1915. p. 364.
- C. A. Culver. A Few Experiments with Ground Antennae. *Proc. I. R. E.*, 4, 455, October 1916.
- C. A. Culver. Notes on Radiation from Horizontal Antenna. *Proc. I. R. E.* 4, 449, October 1916.
- B. F. Meissner. Radio Dynamics. (Book). 1916. p. 186.
- M. Siegbahn. Electromagnetic Waves in Coils with Distributed Capacity. *Archiv. f. Elektrotechnik*, 4, 305-313, (1916). *Sci. Abs. A*, No. 1067, 1916. Refers to article by K. W. Wagner. *Sci. Abs. B*, No. 659, 1915. See also Fleming *Sci. Abs. A*, No. 2683 (1904).
- A Unilateral Directive Aerial, British Patent 24098 of 1914. *Engineer* 121, 165, F. 18, 1916. *Sci. Abs. B*, No. 244, March 1916. Aerials differing in phase.
- E. Bennett, Univ. of Wisconsin. High Versus Low Antennae in Wireless Telegraphy and Telephony. *Bull.* (No. 810 of Eng. Series). Vol. 8, Nov. 4, *Electrician* 79, pp. 18-20, April 6, 1917.
- Marley Fotheringham Hay. Secrets of the Submarine. (Book). Dodd, Mead & Co., N. Y. 1917.
- John H. Morecroft. Some Experiments with Long Electrical Conductors. (With particular reference to radio antennas). *Proc. I. R. E.* 6, 389, 1917.
- Rushmore. Bibliography of the Literature of Submarines. *G. E. Review*, August 1917.
- Alexandre Arton. A New Kind of Directive Antenna. French Patent 485622. *Rev. Gen. d'El.* 4, 99D., Sept. 28, 1918.
- E. Bennett. Feasibility of the Low Antenna in Radio Telegraphy. *Proc. I. R. E.* Vol. 6, page 238, 1918.
- J. Joly. A Method of Avoiding Collision at Sea. *Proc. Roy. Soc.* 94, 547, 1918.
- J. B. Pomey. Capacité d'une Antenne Horizontale. *Rev. Gen. d'El.* 4, 790-792, Nov. 23, 1918. (Derivation of Pederson formula by use of complex quantities).
- L. Zehnder. Horizontal Antennas. *Elektrotechnische Zeitschrift*, 52, 515-516, Dec. 26, 1918.
- Max Abraham. Die Strahlung von Antennen Systemen. *Jahrbuch* 14, 146-152, July 1919.
- E. F. W. Alexanderson. Simultaneous Sending and Receiving. *Proc. I. R. E.* 7, 363, August 1919.
- Thomas G. Alvord. Radio Messages to Submarines from Shore or Sea Discovered by Accident in War Experiment. *New York Herald*, August 10, 1919.
- L. W. Austin. Quantitative Experiments with Coil Antennas.

**Direction Finder** Locates Ship with Great Accuracy. *Wireless Age*, 6, 10, June 1919.

**Direction Finding** by Wireless. *London Times Eng. Sup.* June 1919.

**Artom's Visual Receiver** for Directive Wireless Telegraphy. *Wireless Age*, 21, August 1919.

Richtungsbestimmung im Flugzeug mittels drahtlosen Telegraphic, *Luftfahrt* 23, April 1919.

**Marconi Radiometer.** *Electrician* 83, 142, August 8, 1919.

**La Radiogoniometrie.** *R. G. E.* 6, 112D, Nov. 1, 1919. *La Nature*, June 28, 1919. p. 404-414.

The U. S. Navy Radio Compass. *Everyday Engineering*, 8, 109-11, Nov. and Dec., 1919.

Radiogoniometre. *La Nature*. No. 2361. 404-414, June 28, 1919.

Rogers' Underground Aerials. *Wireless Age*, 6, 31, August 1919.

The United States Naval Communication Service. *Journal of the Franklin Institute*, 188, 751, Dec. 1919.

How Bureau of Standards Helped Win the War. *Washington Star*, August 24, 1919.

The Submarine's Under-Water Radio. *Electrical Experimenter* 7, 539, October 1919. November 1919, 7, p. 661.

Ralph R. Batcher. Loop Antenna for Submarines. *The Wireless Age*, 7, 28, Jan. 1920.

A. Hoyt Taylor. The Use of Ground Wires at Remote Control Stations. *Proc. I. R. E.*, 1920.

---

## Discussion

**H. H. Beverage:** Since the wave antenna paper was written, more quantitative measurements have been made on the effective height of the wave antenna. The measurements mentioned

in the paper gave the ratio of horizontal to vertical voltage gradient as 30 per cent. This measurement was based on comparatively few observations and was not checked simultaneously against an antenna of known effective height. Furthermore, the measurements were based on vertical gradients calculated by Austin's formula, which gives values much lower than observed values at certain periods of the day.

Recently, a much more accurate quantitative method has been developed for measuring signal intensity, and many measurements have been made on the wave antenna at Belmar. In this case, the effective height of the wave antenna was determined by simultaneous observations on a vertical antenna of known effective height. Measurements made by H. H. Beverage and H. O. Peterson indicated that the average effective height of the Belmar long wave antenna was 200 meters. Since the horizontal length was 12,500 meters, the horizontal potential gradient is 1.6 per cent of the vertical potential gradient. At 11,000 meters, the effective height was somewhat greater than this average value, and at 19,000 meters the effective height was lower than the average value. These observations give the same order of magnitude as the calculations by Zenneck's formula for wave tilt.

On short wave lengths, that is, 200 to 600 meters, the horizontal gradient appears to be around 5 per cent to 6 per cent of the vertical gradient over soil of moderately low conductivity such as is found at Belmar. This increase in tilt with shorter wave length is in accordance with Zenneck's formula.

A further check on the wave tilt theory has been noted by comparing the effective height of short wave antennas over earth of high and low conductivity. These antennas were about 400 meters long, and measurements made by Peterson on 400 meters indicated that the signal strength on an antenna over moderately conducting ground was three to four times as great as on a similar antenna partly over salt water and partly over a marsh. In this case, comparisons were made directly with a local loop in order to check the field intensity in the vicinity of the wave antennas.

---

*Jnl. Wash. Acad. Sci.* 9, 335-339, June 19, 1919. *Rev. Gen. d'El.* 6, 551, October 25, 1919. *El. Wld.* 74, 311, August 9, 1919.

E. Bellini. Un Radiogoniometre Electrostatique, R. G. E. VI 122D, Nov. 1, 1919. *Electrician*, Sept. 12, 1919. LXXXIII, p. 273-275.

A. Blondel. On the Goniometric Functions Applicable to Directive Aerials. *Radio Review* 1, 1-10, Oct., 1919.

A. Blondel. On the Electric Functions Applicable to Directive Aerials. *Tech. Review, Eng. Index* 6, 198, Nov. 25, 1919. *Radio Review*, Nov. 1919.

A. Blondel. On the Goniometric Functions Applicable to Directive Aerials. *Radio Reviews* I, 58-66, November 1919.

A. S. Blatterman. Theory and Practical Attainments in the Design and Use of Radio Direction Finding Apparatus Using Closed Coil Antennas. *Journal of the Franklin Institute* 188, 289-362, Sept. 1919.

A. S. Blatterman. Radio Direction Finding Apparatus. *Electrical World* 73, 464, 1919.

P. H. Boucheron. Guarding the Ether During the War—the Radio Compass. *Radio Amateur News*, 1, 104, Sept. 1919.

David S. Brown. Loop Antennae and Direction Finders for Amateur Use. *Radio Amateur News*, 1, 60, August 1919.

J. S. Brown. Underground Antennas. *Radw Amateur News* July 1919.

J. Stanley Brown. Design of Rogers "Ground" Antenna. *Radio Amateur News*, 1, 10, July 1919.

W. Burstyn. Die Strahlung und Richtwirkung einiger Luftdrahtformen in freien Raume. *Jahrb. d. drahtl. Tel.* 13, 362-378, Jan. 1919.

W. Burstyn. Die Schleife als Empfänger. *Jahrbuch* 13, 378-385, Jan. 1919. *Elec. World*, 73, 1177, May 31, 1919. *Sci.* Abs. B, No. 481, June 1919.

Capt. C. A. Culver. Transatlantic Radio Reception. *Journal of the Franklin Institute*, May 1919, p. 578.

J. H. Dellinger. Radio Transmission Formulas for Antenna and Coil Aerials. *Journ. Franklin Institute* 188, 95-96, July 1919.

J. H. Dellinger. Principles of Radio Transmission and Reception with Antenna and Coil Aerials. *Scientific Paper of the Bureau of Standards*, No. 354, December 11, 1919.

J. H. Dellinger. Bureau of Standards Radio Work. *The Federal Employes* 4, 590, Oct. 11, 1919. Reprinted in *Cleveland Plain Dealer*, Nov. 23, 1919.

A. K. Dyall. Workings of the Radio Compass. *Popular Science Monthly* 95, 116, Sept. 1919.

W. H. Eccles. Wireless Telegraphy and Telephony. (Book). p. 134.

R. A. Fessenden. The Fessenden Pelorus. (Wireless Compass). A Caution as to its Use. *Electrician* 83, 719, Dec. 19, 1919.

A. O. Gibbon. Wireless Telephony and Direction Finding Demonstrations. Post Office El. Eng, July 12, 1919, 101-104.

John Hays Hammond, Jr. Aero Radio Surveying and Mapping. *Flying* 8, 160, 184, March 1919.

Walter J. Henry. A Loop of Wire. *Sci. American* 120, 362, Oct. 11, 1919.

W. J. Henry. The Priess Loop Set. *Radio Amateur News*, 1, 270, Dec. 1919.

Charles D. Herrold. Experiments on Ground Antenna with their Relation to Atmospherics. *Radio Amateur News*, 1, 11, July 1919.

E. T. Jones. Underground Radio Made Possible for the Amateur. *Radio Amateur News*, 1, 274, Dec. 1919.

E. T. Johnstone. A Radio Goniometer. *Radio Amateur News*, 1, 179, October 1919.

L. M. Knoll. Concentrated or Loop Aerials. *Electrical Experimenter* 7, 328, August 1919.

Jerome Lachenbruch. The Wireless Compass. *Sci. Am.* 120, 291, March 22, 1919.

Jerome Lachenbruch. Radiogoniometer. *Elec. Rev.* (London) April 25, 1919.

Marconi and Franklin's Directive Radio System. *Wireless Age*, 6, 20, Sept. 1919.

A. Meissner. Über die Bestimmung der Eigenschwingung von Antennen. *Jahrbuch* 14, 269-270, August 1919.

A. Meissner. Über die Bestimmung der Eigenschwingung von Antennen. *Phys. Ztschft.* 20, 130-131, March 15, 1919.

L. A. Pollock. Value of Radio Compass Invented by F. A. Kolster. *Radw Am. News* 1, 136, Sept. 1919.

Capt. J. Robinson. Directional Wireless with Special Reference to Aircraft. *Radio Review* 1, 39, Oct. 1919.

J. Robinson. Direction Finders for Aircraft. (British Association Paper). *Wireless World* 7, 475, Nov. 1919.

Robinson's Manual of Radio Telegraphy and Telephony. Fifth edition (1919) p. 173.

J. J. Rogers. International Submarine and Radiocommunication as Related to American Commerce. *Telegraph & Telephone Age*, Dec. 16, 1919, p. 614-417.

H. R. S. Sankey. Wireless Direction Finders. *Engineering* 108, 523, Oct. 17, 1919. Lecture at Olympia Ex. Oct. 9, 1919. *Tech. Rev.* 6, 182, Nov. 25, 1919.

H. R. S. Sankey. Direction Finding by Wireless Telegraphy. *Elec. Rev.* 86, 509, Oct. 17, 1919. Abs. lecture, Shipping Exhibition.

H. R. Shankey. Direction Finding by Wireless Telegraphy. *Elec. Rev.* 86, 539, Oct. 24, 1919. Abst. lecture, Shipping Exhibition.

H. R. Sankey. Wireless Direction Finders. *Engineering* (London). 108, 523, Oct. 17, 1918.

H. Winfield Secor. The Rogers Underground Wireless. *Electrical Experimenter*, 6, March 1919.

Martin D. Stevers. Working Radio Underwater and Underground. *Illustrated World*, June 1919.

H. de F. Stevers. Submarine Radiotelegraphy. *Armour Eng.* 11, 12-16, Nov. 1919.

Geo. O. Squier. (Editorial) Airplane Direction Finder a Development of the War. *Electrical World* 73, 222, Feb. 1, 1919.

Martin D. Stevers. Working Radio Underwater and Underground. *Illustrated World*, 31, 539, June 1919.

A. Hoyt Taylor. The Possibilities of Concealed Receiving System. *Proc. I. R. E.* 7, 261-266, June 1919.

A. Hoyt Taylor. Subterranean and Submarine Antennae. *Elec. Review* 85, 620, Nov. 14, 1919. *Proc. I. R. E.*

A. Hoyt Taylor. Short-Wave Reception and Transmission on Ground Wires. (Subterranean and Submarine). *Proc. I. R. E.* 7, 337, August 1919.

A. Hoyt Taylor. Long-Wave Reception and the Elimination of Strays on Ground Wires. (Subterranean and Submarine). *Proc. I. R. E.* 7, 559, December 1919.

Roy A. Weagant. Reception Through Static and Interference. *Proc. I. R. E.* 7, 207-256, June 1919.

J. A. Willoughby and P. D. Lowell. Development of Loop Aerials for Submarine Radio Communication. *Phys. Rev.* 14, 193, August 1919.

Unidirectional Transmitting System. *Wireless Age* 6, 19-20, June 1919.

Directional Effect of Radio Useful in Transatlantic Aircraft Flight. *Wireless Age*, 6, 9, June 1919.

Loop Antenna Used Thirteen Years Ago. *Everyday Engineering* 8, p. 111, Nov. and Dec. 1919.

The Loop Fallacy. *Q. S. T.* 3, 23, September 1919.

Navigation by Direction Finding Apparatus. *Wireless World*, 7, 105, May 1919.

The Marconi Direction Finder. *Electrician* 83, 142-143, Aug. 9, 1919. Describes standard Marconi apparatus. *Elec. World* 74, 770, Oct. 4, 1919.

Field Wireless Telephony and Direction Finding. *Wireless World* 7, 199-205, July 1919.